



# New Brunswick™ Innova® 42/42R Shaker

Operating manual

## **Copyright**

Copyright © 2014 Eppendorf AG, Germany. No part of this publication may be reproduced without the prior permission of the copyright owner.

The company reserves the right to change information in this document without notice. Updates to information in this document reflect our commitment to continuing product development and improvement.

## **Trademarks**

Eppendorf® and the Eppendorf logo are registered trademarks of Eppendorf AG, Germany.

New Brunswick™ is a trademark of Eppendorf AG, Germany.

Innova® is a registered trademark of Eppendorf, Inc., USA.

Windows® is a registered trademark of Microsoft Corporation in the United States and other countries.

Trademarks are not marked in all cases with ™ or ® in this manual.

## Table of contents

<b>1</b>	<b>Operating instructions</b>	<b>7</b>
1.1	Using this manual	7
1.2	Danger symbols and danger levels	7
1.2.1	Hazard symbols	7
1.2.2	Degrees of danger	7
1.3	Symbols used	8
<b>2</b>	<b>Safety</b>	<b>9</b>
2.1	Intended use	9
2.2	User profile	9
2.3	Application limits	9
2.3.1	Description of ATEX Guideline (94/9EC)	9
2.4	Information on product liability	10
2.5	Warnings for intended use	10
2.5.1	Personal injury and damage to device	10
2.5.2	Incorrect handling of accessories	11
<b>3</b>	<b>Product description</b>	<b>13</b>
3.1	Main illustration	13
3.2	General overview	14
3.3	Controls	16
3.4	LCD Display	17
3.5	Changing screens	17
3.6	Display icons	19
3.7	Alarms	19
3.8	Door operation	20
3.9	Spill containment	20
3.10	Software interfaces	20
3.11	Interior lamps	20
3.12	Heater	20
3.13	Refrigeration (42R only)	21
3.14	Service accessibility	21
3.15	Optional remote alarm	21
3.16	Optional gassing manifold kit	21
3.17	Optional germicidal UV lamp	22
3.18	Optional photosynthetic growth lamps	22
3.19	Optional humidity monitor	22
3.20	Optional culture drawer	23
<b>4</b>	<b>Installation</b>	<b>25</b>
4.1	Inspection of boxes	25
4.2	Packing list verification	25
4.3	Unpacking of equipment	25
4.4	Out of box concerns	25
4.5	Physical location	25
4.6	Environment	26
4.7	Electrical requirements	26
4.8	Space requirements	26

**Table of contents**

New Brunswick™ Innova® 42/42R Shaker  
English (EN)

4.9	Platform installation . . . . .	27
4.10	Flask clamp installation . . . . .	27
4.11	Electrical connections . . . . .	29
4.12	Optional culture drawer . . . . .	29
4.13	Stacking instructions . . . . .	30
4.13.1	Stacking Kit . . . . .	30
4.13.2	For two Innova 42/42R shakers . . . . .	32
4.13.3	For an Innova 4200/4230 on an Innova 42/42R . . . . .	37
<b>5</b>	<b>Operation . . . . .</b>	<b>39</b>
5.1	Platform assemblies . . . . .	39
5.2	Installation of platform . . . . .	39
5.3	Safety precautions . . . . .	40
5.4	Fill the drip pan reservoir . . . . .	40
5.5	Drain the drip pan reservoir . . . . .	41
5.6	Start the shaker . . . . .	41
5.7	Using the LCD screens . . . . .	41
5.7.1	Display screen . . . . .	41
5.7.2	Summary screen . . . . .	44
5.7.3	Setup screen . . . . .	46
5.7.4	Lamps screen . . . . .	47
5.7.5	RS232 screen . . . . .	48
5.7.6	Calibrate screen . . . . .	50
5.7.7	Programs screen . . . . .	51
5.8	Programming the shaker . . . . .	51
5.8.1	Timer only . . . . .	51
5.8.2	Programmed steps . . . . .	51
5.8.3	Create a program . . . . .	52
5.8.4	Edit a program . . . . .	55
5.8.5	Run a program . . . . .	56
5.9	Mute the audible alarm . . . . .	56
5.10	Temperature offset calibration . . . . .	57
5.10.1	Calculate the offset value . . . . .	57
5.10.2	Set the offset . . . . .	57
5.11	Using Calspeed . . . . .	58
5.12	Power interruption . . . . .	59
<b>6</b>	<b>Troubleshooting . . . . .</b>	<b>61</b>
6.1	General troubleshooting . . . . .	61
<b>7</b>	<b>Maintenance . . . . .</b>	<b>63</b>
7.1	Routine maintenance . . . . .	63
7.2	Cleaning external and internal surfaces . . . . .	63
7.3	Biohazard decontamination . . . . .	63
<b>8</b>	<b>Technical data . . . . .</b>	<b>65</b>
8.1	Specifications . . . . .	65
8.1.1	Shaking . . . . .	65
8.1.2	Temperature control . . . . .	65
8.1.3	Power supply . . . . .	66

8.1.4	Dimensions . . . . .	66
8.1.5	Weight. . . . .	66
8.1.6	Ambient conditions . . . . .	66
8.1.7	CE regulatory standards . . . . .	66
8.1.8	ETL regulatory standards . . . . .	66
8.1.9	Features. . . . .	67
8.1.10	Fuses . . . . .	67
8.2	Load/speed graphs . . . . .	67
8.3	Using ancillary equipment with the Innova 42/42R . . . . .	70
8.3.1	Electrical moisture-proof plug . . . . .	71
<b>9</b>	<b>Ordering information . . . . .</b>	<b>73</b>
9.1	Replacement parts . . . . .	73
9.2	Accessories . . . . .	73
9.2.1	Platforms . . . . .	73
9.2.2	Flask clamps for universal platforms . . . . .	74
9.2.3	Replacement clamp hardware. . . . .	74
9.2.4	Test tube racks and other accessories . . . . .	75
<b>10</b>	<b>Transport, storage and disposal . . . . .</b>	<b>77</b>
10.1	Transport and storage. . . . .	77
10.2	Disposal. . . . .	77
<b>11</b>	<b>Appendix A: Remote programming. . . . .</b>	<b>79</b>
11.1	Setting up with HyperTerminal. . . . .	79
11.2	Overview of command sets . . . . .	79
11.3	Index to command codes . . . . .	81
11.4	Set commands. . . . .	81
11.5	Profile control commands. . . . .	81
11.6	Report request commands . . . . .	82
11.7	Set/Get date and time . . . . .	83
	<b>Index . . . . .</b>	<b>84</b>
	<b>Certificates . . . . .</b>	<b>87</b>

**Table of contents**

New Brunswick™ Innova® 42/42R Shaker  
English (EN)







# 1 Operating instructions

## 1.1 Using this manual

- ▶ Carefully read this operating manual before using the device for the first time.
- ▶ Also observe the operating manual enclosed with the accessories.
- ▶ The operating manual should be considered as part of the product and stored in a location that is easily accessible.
- ▶ When passing the device on to third parties, be sure to include this operating manual.
- ▶ If this manual is lost, please request another one. The current version can be found on our website [www.eppendorf.com](http://www.eppendorf.com).

## 1.2 Danger symbols and danger levels

### 1.2.1 Hazard symbols

 <p><b>Hazard point</b></p>	 <p><b>Burns</b></p>
 <p><b>Electric shock</b></p>	 <p><b>Material damage</b></p>
 <p><b>Explosion</b></p>	 <p><b>Heavy loads</b></p>
 <p><b>Inhalation</b></p>	

### 1.2.2 Degrees of danger

The following degree levels are used in safety messages throughout this manual. Acquaint yourself with each item and the potential risk if you disregard the safety message.

<b>DANGER</b>	<i>Will</i> lead to severe injuries or death.
<b>WARNING</b>	<i>May</i> lead to severe injuries or death.
<b>CAUTION</b>	May lead to light to moderate injuries.
<b>NOTICE</b>	May lead to material damage.

**Operating instructions**

New Brunswick™ Innova® 42/42R Shaker  
English (EN)

### 1.3 Symbols used

Example	Meaning
▶	You are requested to perform an action.
1. 2.	Perform these actions in the sequence described.
•	List.
	References useful information.



## 2 Safety

### 2.1 Intended use

This device is exclusively intended for indoor use and for uniform movement and temperature control of biological solutions and cultures in reaction vessels.



#### **CAUTION! Lack of safety due to incorrect accessories or spare parts**

Accessories and spare parts that are not recommended by Eppendorf compromise the safety, function and precision of the device. Eppendorf cannot be held liable or accept any liability for damage resulting from the use of non-recommended accessories and spare parts.

- ▶ Only use accessories and original spare parts recommended by Eppendorf.
- 

### 2.2 User profile

The device may only be operated by trained lab personnel who have carefully read this operating manual and are familiar with the device functions.

### 2.3 Application limits

#### 2.3.1 Description of ATEX Guideline (94/9EC)



#### **DANGER! Explosion hazard**

- ▶ Do not operate the device in areas where work is completed with explosive substances.
  - ▶ Do not use this device to process any explosive or highly reactive substances.
  - ▶ Do not use this device to process any substances which could create an explosive atmosphere.
- 

Due to its design and the ambient conditions in its interior, the device is not suitable for use in potentially explosive atmospheres.

The device may only be used in a safe environment, e.g., the open atmosphere of a ventilated lab.

The use of substances which may contribute to a potentially explosive atmosphere is not permitted.

The final decision regarding the risks associated with using these types of substances is the user's responsibility.

## 2.4 Information on product liability

In the following cases, the designated protection of the device may be compromised.

The liability for the function of the device passes to the operator if:

- The device is not used in accordance with this operating manual.
- The device is used outside of the range of application described in the succeeding chapters.
- The device is used with accessories or consumables that were not approved by Eppendorf.
- Service or maintenance is completed on the device by people who are not authorized by Eppendorf.
- The owner has made unauthorized modifications to the device.

## 2.5 Warnings for intended use

Before using the device, read this operating manual and observe the following general safety instructions.

### 2.5.1 Personal injury and damage to device



#### **WARNING! Electric shock due to damage to the device or power cable**

- ▶ Only switch on the device if the device and power cable are undamaged.
- ▶ Only use devices that have been properly installed or repaired.



#### **WARNING! Lethal voltages inside of the device**

- ▶ Ensure that the housing is always closed and undamaged so the user cannot accidentally touch the parts inside.
- ▶ Do not remove the housing of the device.



#### **WARNING! Danger due to incorrect power supply**

- ▶ Only connect the device to voltage sources that meet the requirements on the name plate.
- ▶ Only use sockets with a protective earth (PE) conductor and suitable power cable.



#### **WARNING! Health risk due to contact with infectious liquids and pathogenic bacteria**

- ▶ Observe the national regulations for handling these substances, the biological security level of your laboratory, the material safety data sheets and the manufacturer's application notes.
- ▶ Wear personal protective equipment (PPE).
- ▶ Follow the instructions regarding hygiene, cleaning and decontamination.
- ▶ For complete instructions on the handling of germs or biological material in risk group II or higher, please refer to the "Laboratory Biosafety Manual" (source: World Health Organization).



**WARNING! Health risk due to poisonous, radioactive or aggressive chemicals**

- ▶ Observe the national regulations for handling these substances as well as the material safety data sheets and manufacturer's application notes.
- ▶ Wear personal protective equipment (PPE).



**WARNING! Burns due to hot metal on the device and hot flasks**

- ▶ Only touch the device and flasks when wearing protective gloves.



**WARNING! Risk of crushing due to missing auxiliary aid**

- ▶ Lifting and transporting the shaker without suitable technical aids can result in crushing and other injuries.
- ▶ Use a hydraulic lifting platform to install and uninstall the shaker.



**CAUTION! Risk to health due to lifting heavy loads**

- ▶ Only lift the device with another person or using a suitable aid.
- ▶ Make sure to use a transport aid for transportation over long distances.



**NOTICE! Damage to electronic components due to condensation**

Condensation can form inside the device after the device has been moved from a cool to a warmer environment.

- ▶ Wait at least 3 h before connecting it to the mains/power supply.

## 2.5.2 Incorrect handling of accessories



**CAUTION! Lack of safety due to incorrect accessories or spare parts**

Accessories and spare parts that are not recommended by Eppendorf compromise the safety, function and precision of the device. Eppendorf cannot be held liable or accept any liability for damage resulting from the use of non-recommended accessories and spare parts.

- ▶ Only use accessories and original spare parts recommended by Eppendorf.



**NOTICE! Danger due to damaged tubes**

Small scratches and cracks can cause severe damage to the device and accessories. Liquids may escape.

- ▶ Before use, visually check all tubes for any damage.
- ▶ Never use damaged tubes.

**Safety**

New Brunswick™ Innova® 42/42R Shaker  
English (EN)

### 3 Product description

#### 3.1 Main illustration

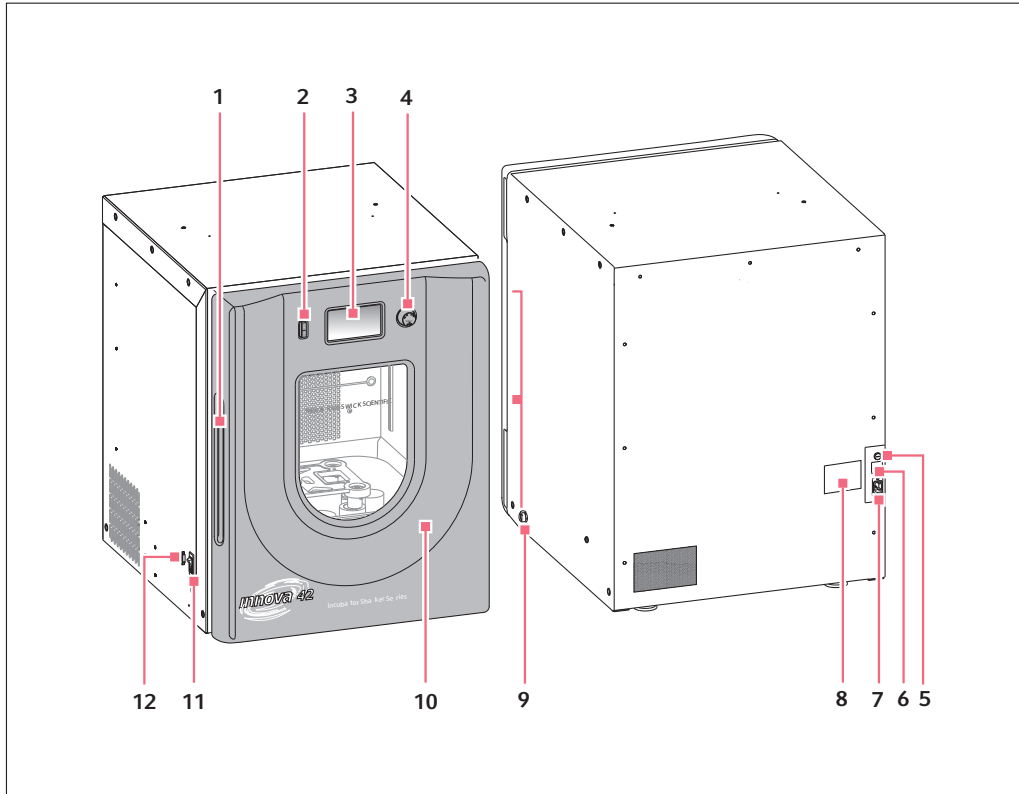

Fig. 3-1: Front and rear view of the Innova 42/42R

- |  |   |
|--|---|
| <b>1 Door handle</b>   | <b>7 Mains power connection</b><br>Connect the power cable  |
| <b>2 Start/Stop switch</b><br>Starts or stops drive  | <b>8 Name plate</b><br>Model number, documentation number, serial number and electrical connection data               |
| <b>3 Display</b><br>Graphical user interface with display of parameters and parameter values | <b>9 Quick coupling</b><br>Connect the coupler plug to the discharge hose   |
| <b>4 Push button control knob</b><br>Set or change the parameters or Starts or stops drive   | <b>10 Door</b><br>With automatic stop function  |
| <b>5 Fuse</b><br>Fuse clip   | <b>11 Mains power switch</b><br>Switch device on or off   |
| <b>6 Fuse label</b><br>The size of the fuse depends on the power connection                  | <b>12 RS-232 interface</b><br>Read out parameter values and control operational functions using computer applications |

**Product description**

New Brunswick™ Innova® 42/42R Shaker  
English (EN)

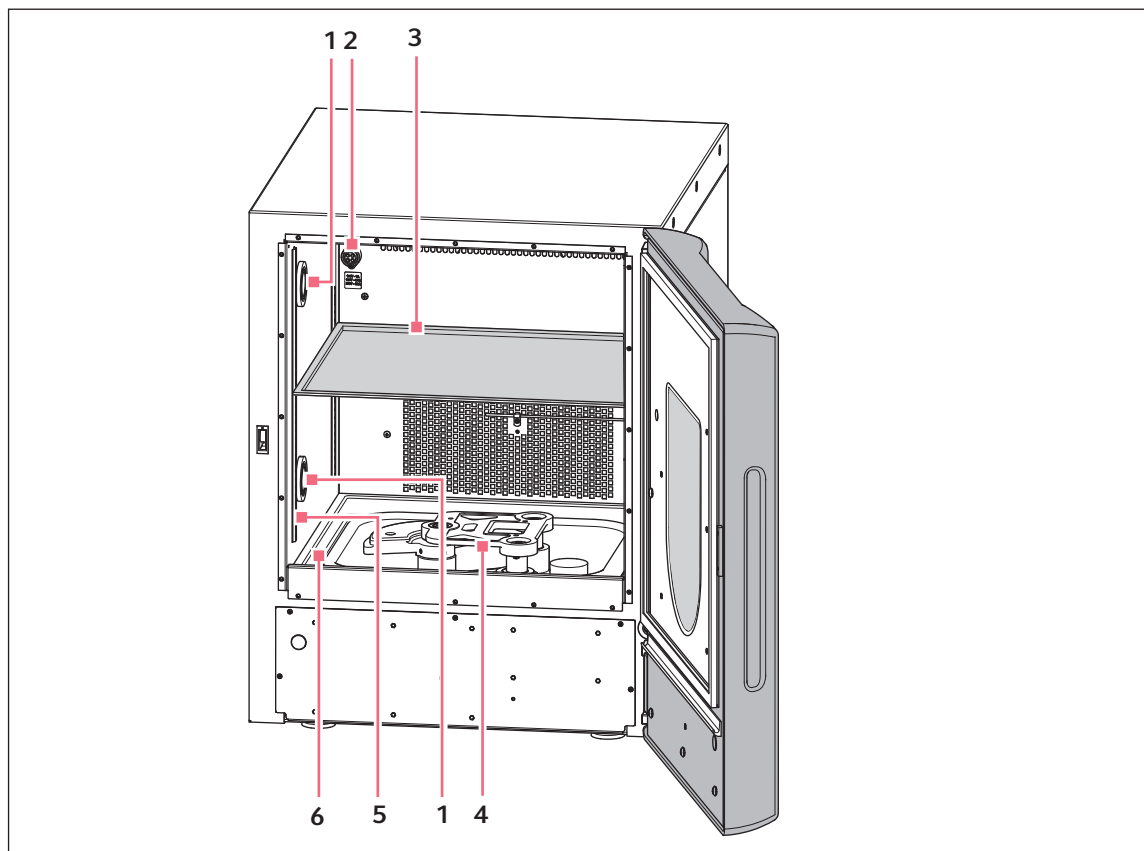

Fig. 3-2: Internal view

**1 Halogen lighting****2 Power Socket**

Moisture-proof for additional devices or photosynthetic lamps

**3 Removable shelf****4 Drive**

Triple eccentric drive - orbit is model-dependent.

**5 Perforated rail**

With clips for removable shelf or culture drawer

**6 Drip pan and reservoir**

Catch liquids and store water for humidification

### 3.2 General overview

The Innova 42/42R Incubator Shakers are benchtop or floor mounted stackable orbital shakers that utilize a triple eccentric counter-balanced drive mechanism. They provide horizontal plane rotary motion in either a 1.9 cm (3/4 in) or a 2.54 cm (1 in) diameter circular orbit, depending on the model. A Proportional/Integral (PI) microprocessor controller with instantaneous digital feedback controls the speed over the entire speed range.

The Innova 42R (refrigerated model) provides temperature control from 20 °C below ambient (with a minimum setpoint of 4 °C) to 80 °C, and the Innova 42 (incubated model) from 5 °C above ambient to 80 °C.

Naturally, both these ranges depend on relative humidity and other ambient factors, as well as the options installed in the unit. Ambient temperature is measured at 1 m from the exterior of the unit.

Erlenmeyer flasks (up to 6 L in size), and a wide variety of tubes and plates can be accommodated using the Eppendorf shaker accessories described in a later paragraph (see *Accessories on p. 73*).

The Innova 42/42R may be operated in the following ways:

- **Continuously:** at a set speed and temperature, until user intervention.
- **In a timed mode:** run at a set speed, time and temperature for a period of up to 99.9 h, after which the shaker automatically shuts off.
- **Via the shaker's programmable controller:** run through multiple temperature and speed changes for an extended period of time.
- **Via computer through an RS-232 interface.**

For safe operation, the Innova 42/42R shakers are designed with a safety switch that automatically stops the shaker mechanism when the door is opened.

The Innova 42/42R is equipped with visual and audible alarms that alert the user to the following conditions:

- The end of a timed run
- Deviations from speed setpoint
- Deviations from temperature setpoint
- Power failure
- Door open

To accommodate customer needs, a wide variety of platforms can be used with the Innova 42/42R:

- Universal platforms are the most flexible, providing hole patterns for flask clamps, test tube racks and other accessories.
- Dedicated platforms are supplied with flask clamps attached; they are designed solely and expressly for this purpose.
- Test tube racks, microplate holders, and test tube rack holders are also available (a universal platform is needed for all test tube racks and holders).

For further information on these accessories, (see *Accessories on p. 73*).

**Product description**

New Brunswick™ Innova® 42/42R Shaker  
English (EN)

**3.3 Controls**

Fig. 3-3: Front Panel (detail)

**1 Start/Stop Switch**

**2 Display**

**3 Control Knob**

**4 Power Switch (on side panel)**

**5 RS-232 Port (on side panel)**

- **START/STOP SWITCH:** This switch is used to start or stop the shaker agitation. It will also activate the timer when a timed run is desired. If the unit is stopped and restarted, the timer automatically returns to the beginning of a run.
- **CONTROL KNOB:** This knob is multifunctional. It is used to change screens, and to select and change operating conditions.
- **RS-232 PORT:** For details, (see *Software interfaces on p. 20*).
- **POWER SWITCH:** This rocker switch is a circuit breaker that turns power on and off to the entire Innova 42/42R.



In addition to the power switch, the power cord is also used to conduct power or to break the power circuit to the shaker. Whenever power to the shaker may be a hazard (during cleaning, maintenance or service work), be sure to disconnect the power cord from the electrical outlet.



### 3.4 LCD Display

When the unit is powered up, using the Power Switch located on the front panel (see Fig. 3-3 on p. 16), the initial display screen will remain for a short time while the system boots up.

Then the main screen, called **DISP** for Display, appears (see Fig. 3-4 on p. 17). This screen will indicate the same parameters that were in effect when the power was turned off.

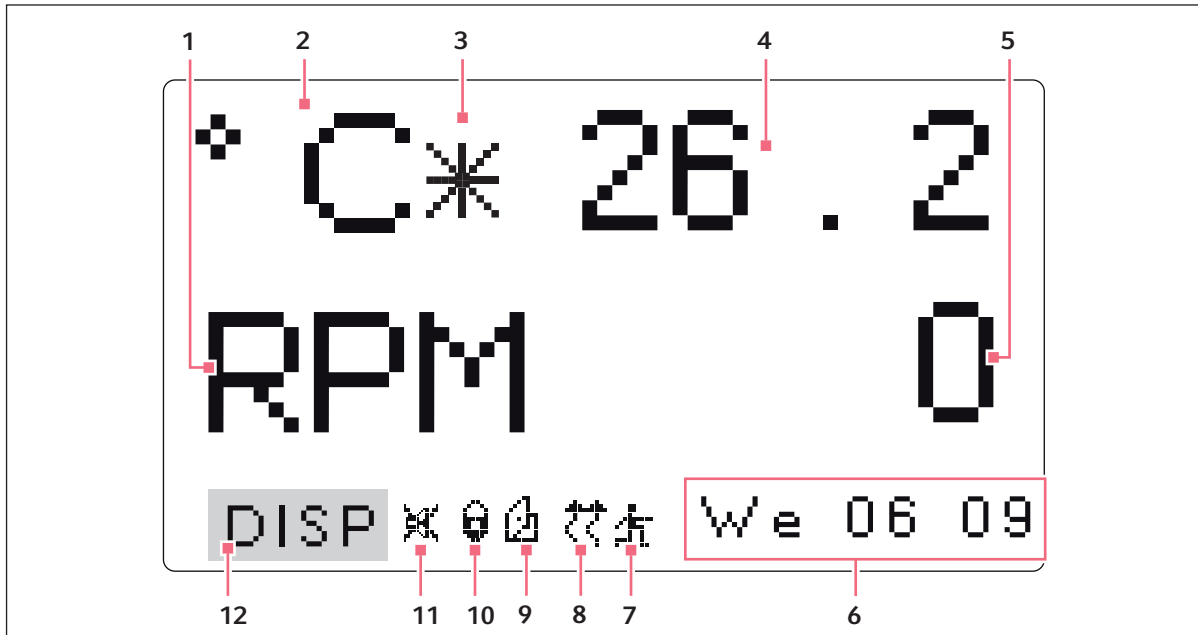

Fig. 3-4: Display Screen

- |                           |                       |
|---------------------------|-----------------------|
| 1 Actual Parameter Values | 6 Parameters Locked   |
| 2 Day and 24-Hour Time    | 7 Audible Alarm Muted |
| 3 Program Running         | 8 Screen Name         |
| 4 Heater On               | 9 Parameters          |
| 5 Door Open               | 10 Temperature Offset |

- For an explanation of the icons on the display screen, (see *Display icons on p. 19*).
- Turning the Control Knob will highlight functions and/or values that can be changed.

For more information on working in the Display Screen, (see *Display screen on p. 41*).

### 3.5 Changing screens

You can change screens displayed by highlighting the screen name field in the lower left corner, pressing the Control Knob in until it clicks (the screen name will flash), rotating the Knob left or right (which also

**Product description**

New Brunswick™ Innova® 42/42R Shaker  
English (EN)

makes clicking sounds) to the desired screen and clicking the Control Knob in again. The Table below describes the various screens:

Screen Name	Meaning	Features/Modes
DISP	Display	Shows 2 user-selectable parameters <sup>1</sup> and actual values.
SUMM	Summary	Shows all parameters <sup>1</sup> , setpoints and actual values.
SET	Set-Up	Set day of week, set time, enable or mute alarm, lock or unlock operating parameters
LAMP	Lamps	<b>Internal chamber lamp:</b> ON (always on); OFF (always off); AUTO (default mode), light goes on and stays on when door is open, shuts off 15 s after door is closed, and goes on for 15 s when Control Knob is moved. <b>Photosynthetic lights (GRO)</b> <sup>2</sup> : ON, OFF, NONE <sup>3</sup> <b>UV lamp (UV)</b> <sup>2</sup> : ON, OFF, NONE <sup>3</sup>
COMM	Communication (RS-232)	SET: set baud rate OFF disables RS-232 MONITOR: PC commands shaker to read setpoints and actual values on a schedule determined by PC software. Parameters are unlocked and can be changed by program or manually. SLAVE: PC controls shaker and logs data. TALK: Shaker sends setpoint and actual data to PC at 1 min intervals.
CAL	Calibration	Allows user to enter a temperature offset. Self-calibrates the speed sensor.
PROG	Program	Allows user to set up 1 – 4 programs, each with 1 – 15 steps.

<sup>1</sup>See Table below

<sup>2</sup>Optional

<sup>3</sup>Not Installed







Parameter Name	Meaning
RPM	Shaking speed, in revolutions per minute
°C	Chamber temperature, in degrees Celsius
HRS	Programmed time remaining, in hours
%RH <sup>1</sup>	Relative Humidity, in percent.
UV <sup>1</sup>	Status of Ultraviolet germicidal lamp
GRO <sup>1</sup>	Status of Photosynthetic growth lamps

<sup>1</sup>Optional

### 3.6 Display icons

There are 6 icons that help identify operating conditions. Five of these icons are located at the bottom of the display, and they are visible, when applicable, in any screen you are viewing, except the Program subscreens. The sixth appears, when applicable, next to °C whenever the temperature is onscreen.

Tab. 3-1: Display Icons

Icon	Explanation
	This icon appears when audible alarms are muted.
	This icon appears when the possibility to make manual or programmed parameter changes is disabled (locked). This is controlled by settings on the SET screen (see <i>Setup screen on p. 46</i> ).
	This icon appears when the shaker door is open.
	This icon appears when the Heater is on (see <i>Heater on p. 20</i> ).
	This icon appears when a user-defined Program is running (see <i>Run a program on p. 56</i> ).
	This icon appears to the right of °C if the Temperature Offset feature is being used (see <i>Temperature offset calibration on p. 57</i> ).

### 3.7 Alarms

If an alarm condition exists, the field in the lower right corner will alternate the Day and Time with characters indicating the nature of the alarm condition, accompanied by an audible alarm (unless muted):

Tab. 3-2: Alarms

Indication	Description
TEMP	The temperature deviates more than 1 °C from setpoint after achieving control temperature range. After door is opened, alarm will be disabled for 5 min while chamber recovers to setpoint.
SPEED	The speed deviates more than 5 rpm from setpoint after achieving operating speed setpoint. After door is opened, alarm will be disabled for 5 min while chamber recovers to setpoint.
POWER	Indicates unit is powering up (both at normal power-up and after power interruption); will flash until the Control Knob is moved.
HRS	Indicates when timed run is completed.

**Product description**

New Brunswick™ Innova® 42/42R Shaker  
English (EN)

### 3.8 Door operation

When the door is opened, the following will happen:

- Heater turns off
- Shaker stops
- Interior lamp goes on and, when it is in AUTO mode, will remain on for 15 s after the door is closed
- UV germicidal lamp (if so equipped) turns off

### 3.9 Spill containment

The Innova 42/42R is equipped with a spill cover and drip pan and reservoir to protect the drive mechanism from accidental spills and/or broken glassware. This pan can also be used as a water reservoir to humidify the chamber and to reduce evaporation. An optional factory-installed humidity monitor is also available.

The reservoir can be drained through the quick-connect valve on the right side of the unit.

### 3.10 Software interfaces

The RS-232 port is located along side of the Power Switch on the right side of the base (see Fig. 3-1 on p. 13). It can be used to interface a computer to the shaker for control of operating conditions or data logging applications (see *Appendix A: Remote programming on p. 79*).

The customer is responsible for securing the proper driver to interface with the RS-232.

### 3.11 Interior lamps

When the LAMP screen is in its default AUTO mode, the interior (“chamber”) lamp is activated for 15 s whenever you turn the Control Knob. It will automatically shut off after 15 s of Control Knob inactivity.

The chamber lamp will also go on when the door is open.

In addition, you can set the chamber lamp to be continuously ON or OFF by selecting either mode in the LAMP screen.

There are 2 additional lamp options for refrigerated units only: interior photosynthetic growth lamps (see *Optional photosynthetic growth lamps on p. 22*) and a germicidal UV lamp located outside the chamber but in the airflow path (see *Optional germicidal UV lamp on p. 22*).

### 3.12 Heater

The chamber temperature is sensed by a 1000 ohm platinum RTD. A 750 W heater is controlled using pulse width modulation on a 2.5-second duty cycle. This cycle time is fast enough to prevent noticeable changes in air temperature due to the cycling.

Whenever the heater is on, the Heater On icon will appear in the display. The heater automatically stops running when the door is opened.

### 3.13 Refrigeration (42R only)

The refrigeration system in the Innova 42R is a variable-capacity system carefully designed with self-checks to maintain the setpoint, to balance pressure within the system, and to keep the evaporator from freezing.

When the shaker is powered up, there is a 4 min time delay prior to compressor start-up.

### 3.14 Service accessibility

In the unlikely event that your Innova 42/42R should need service, all electronic boards, refrigeration and heating components are easily accessible to an authorized service technician.

### 3.15 Optional remote alarm

The Innova 42/42R can be equipped with a factory-installed remote alarm component (Part number M1320-8029). When it is hooked up to your relay and receiving equipment, this device will send notification of an alarm condition to the remote location you choose.

### 3.16 Optional gassing manifold kit

This option is factory-installed. The manifold delivers gas into the chamber via as many as 12 ports. The manifold can be adapted to the desired tubing configuration by adding or subtracting ports or by temporarily clamping off unused tubes. You may elect to use splitters (barbed Y-connectors) after the manifold to increase the number of flasks you can serve. The gas is distributed to your cultures by placing the tubing inside a sealed flask or tube.

You determine the appropriate gas flow rate using a pressure regulator (which you supply) on the gas supply.



**CAUTION! Personnel injury and equipment damage!**

- ▶ Never use the gas manifold with flammable gases.
  - ▶ Regulate the gas supply and never exceed 15 PSI inlet pressure to the manifold.
- 

50 ft (15.2 m) of 1/16 in (1.58 mm) (ID) sterilizable silicone tubing is supplied with the kit. Filters may be needed: 0.22  $\mu$  syringe filters (which you supply) can be fitted to the individual manifold ports to maintain a sterile barrier.

**Product description**

New Brunswick™ Innova® 42/42R Shaker  
English (EN)

### 3.17 Optional germicidal UV lamp

**WARNING! Personnel injury!**

- ▶ Never try to operate the UV Germicidal Lamp while the shaker door is open.

This option, a germicidal ultraviolet lamp, is placed inside the Service Compartment, outside the chamber to help reduce the risk of contamination. The lamp is identified on the display screen as UV.

The UV germicidal lamp is factory-installed and available on refrigerated units only. Operation instructions are provided with this option.

### 3.18 Optional photosynthetic growth lamps

This factory-installed option, available on refrigerated units only, provides 6 photosynthetic growth lamps inside the chamber. They can be turned on and off manually, by the easily set programmable timer, or by computer. These lamps are identified on the display screen as GRO. The replacement bulb part number is P0300-0221.

The recommended operating temperature when using this option is 15 °C – 37 °C; the maximum operating temperature is 70 °C.



When the GRO lamps are on, the unit cannot achieve a chamber temperature lower than 13.5 °C below ambient.



The photosynthetic lamps can be mounted at 2 different height locations.

**Specifications:**

Bulb type and model:	T8 fluorescent
Lumens @ 25 °C:	325
Color Rendering Index (RI):	66

To complement this option, water can be added to the spill pan in order to elevate the humidity level in the chamber (see *Fill the drip pan reservoir on p. 40*).

### 3.19 Optional humidity monitor

This optional factory-installed accessory allows you to monitor relative humidity levels in the chamber throughout your run. When the humidity sensor is present in the chamber, maximum shaker temperature is automatically limited to 60 °C.

**Specifications:**

Humidity Operating Range:	0 to 100 %RH
Temperature Operating Range:	4 °C – 60 °C
Accuracy:	(see Fig. 3-5 on p. 23) Operating Range and Error Graph
Hysteresis:	±1.5 %RH
Recovery Time after Saturation:	10 s
Long Term Stability:	0.5 %RH per year



**CAUTION! Equipment damage!**

- ▶ Operating the Innova 42/42R with humidity sensor at temperatures above 60 °C can result in permanent damage to the sensor.

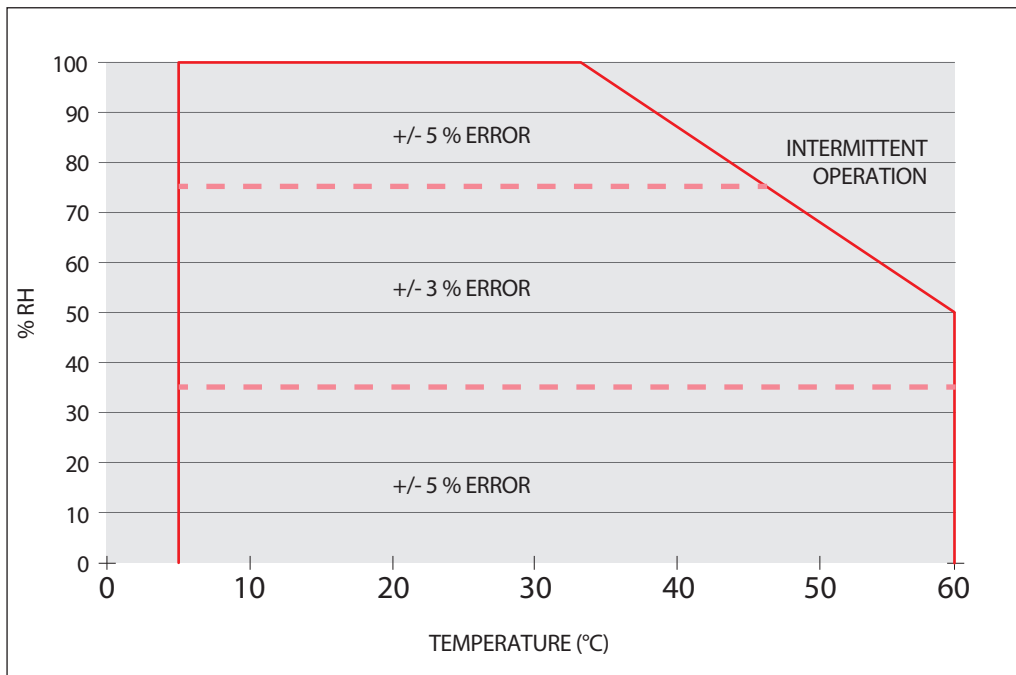

Fig. 3-5: Humidity Sensor Operating Range and Error Graph

### 3.20 Optional culture drawer

The Innova 42/42R can be equipped with a culture drawer that the user installs inside at the top of the cabinet. The culture drawer is designed to reduce sample dessication. This convenient feature allows you to easily access plates, T-flasks and other samples that need incubation but do not need shaking.



When the culture drawer is in place, the largest flask you can place on the platform beneath it is 2 L.

**Product description**

New Brunswick™ Innova® 42/42R Shaker  
English (EN)



The culture drawer must be installed at the top of the cabinet for best results. Installing it in a lower position will block air flow and significantly disrupt temperature uniformity of the cultures on the platform.

**To install the culture drawer:**

1. Install the 4 shelf clips (packaged with the standard shelf) into the rails inside the chamber as you would for the standard shelf. These clips must be at the same height on the rails and near the top of the chamber.
2. Ensure that there is enough clearance to install the Culture Drawer into the chamber.
3. Unwrap the Culture Drawer and gently insert it into the chamber, ensuring that the handle faces outside the chamber.
4. Ease the Culture Drawer into position so that it rests on each of the 4 shelf clips and is well supported.
5. Pull out the Culture Drawer and push it in to test its stability.

Your new Culture Drawer is ready for use.



## 4 Installation

### 4.1 Inspection of boxes

After you receive your order from Eppendorf, inspect the boxes carefully for any damage that may have occurred during shipping. Report any damage immediately to the carrier and to your local Eppendorf Customer Service Department.

### 4.2 Packing list verification

Verify against your Eppendorf packing list that you have received all of the correct materials.

### 4.3 Unpacking of equipment



**WARNING! Personnel injury and equipment damage!**

- ▶ Do not attempt to lift the Innova 42/42R by yourself. Always ask for assistance or use a lifter or other suitable equipment when raising or handling the unit.
- 

Upon unpacking the unit, inspect it carefully for any damage that may have occurred during transit. Report any apparent damage to the carrier and to your Eppendorf sales representative. Save the crate and packing materials.



Use of the Innova 42/42R Shakers requires a platform, which is a separate item. See the Available Platforms list (see *Platforms* on p. 73).

### 4.4 Out of box concerns

If any part of your order was damaged during shipping, is missing pieces, or fails to operate properly, please contact your Eppendorf sales representative.

### 4.5 Physical location



**WARNING! Personnel injury and equipment damage!**

- ▶ Do not attempt to lift the Innova 42/42R by yourself. Always ask for assistance or use a lifter or other suitable equipment when raising or handling the unit.
- 

The surface where you place the Innova 42/42R should be smooth, level and sturdy, and must be able to accommodate 300 lbs.

## Installation

New Brunswick™ Innova® 42/42R Shaker  
English (EN)

### 4.6 Environment

The shaker is designed to operate optimally in the following ambient conditions:

- 10 °C to 35 °C
- 20 % to 80 % Relative Humidity (non-condensing)

### 4.7 Electrical requirements

The Innova 42/42R can be equipped to run on:

- 100 V, 50 Hz, 1500 VA maximum
- 100 V, 60 Hz, 1500 VA maximum
- 120 V, 60 Hz, 1500 VA maximum
- 230 V, 50 Hz, 1500 VA maximum

In all cases, voltage variations must not exceed  $\pm 10$  %.

### 4.8 Space requirements

It is essential that the shaker be situated in an area where there is sufficient space for the unit and its service lines (see Fig. 4-1 on p. 27).

The dimensions of the Innova 42/42R are:

<b>Width</b>	63.50 cm	25 in
<b>Depth</b>	75.43 cm	29.7 in
<b>Height</b>	81.84 cm	32.22 in

The effective surface area required for operation is:

<b>Width</b>	84 cm	33 in
<b>Depth</b>	85 cm	33.5 in



Be sure to allow at least 10 cm (4 in) around shaker for ventilation, access to power cord (rear panel), and access to power switch and RS-232 port (right side).

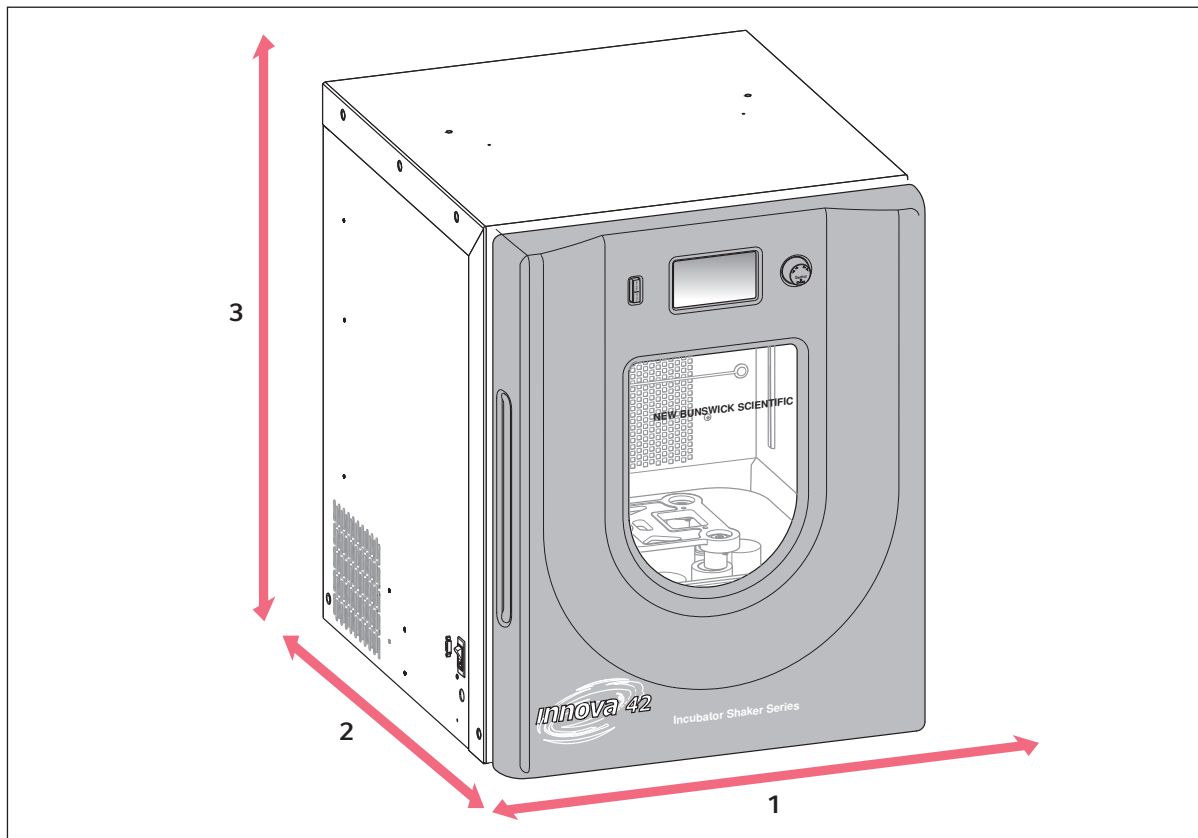

Fig. 4-1: Space Requirements

- 1 Allow 84 cm (33 in) of width to provide clearance for opening the door.
- 2 Allow 85 cm (33.5 in) of depth to provide clearance.
- 3 Allow 84 cm (33 in) of height to provide clearance.

#### 4.9 Platform installation

A platform must be installed on the unit prior to use. For detailed instructions, (see *Installation of platform on p. 39*).



The platform is recommended for speeds up to 400 rpm. For reference, refer to the Load/Speed graphs provided (see *Load/speed graphs on p. 67*).

#### 4.10 Flask clamp installation

Flask clamps purchased for use with universal platforms (see *Platforms on p. 73*) require installation. Clamps are installed by securing the base of the clamp to the platform with the correct type and number of screws. All clamps are shipped complete with hardware.

## Installation

New Brunswick™ Innova® 42/42R Shaker  
English (EN)



The Innova 42 and 42R platforms require 10 – 24 x 5/16 in Phillips-head screws (which are supplied) to fasten flask clamps.

Clamps for 2 L flasks or larger are shipped with an additional girdle to keep the flasks in place. The girdle is an assembly of springs and sections of rubber tubing. One girdle is already in place on the clamp, the other is placed inside the flask clamp. To install these double girdle clamps:

1. Place the clamp on the platform, aligning its mounting holes with holes on the platform. Secure the clamp in place using the flat Phillips head screws provided (#S2116-3051, 10 – 24 x 5/16 in). To help you identify the proper screws, (see Fig. 4-3 on p. 29), as 3 different types of screws are shipped with the clamps.
2. With the first girdle in place, as delivered, on the upper part of the clamp body (see Fig. 4-2 on p. 28), insert an empty flask into the clamp.
3. After making sure the sections of tubing are located between the clamp legs, roll the first girdle down the legs of the clamp as far as it can go. The tubing sections will rest against the platform, and the springs will be under the clamp base.
4. Place the second girdle around the upper portion of clamp body (just as the first girdle was initially). Make sure that its spring sections rest against the clamp legs, while its rubber tubing sections sit against the flask, in between the clamp legs.

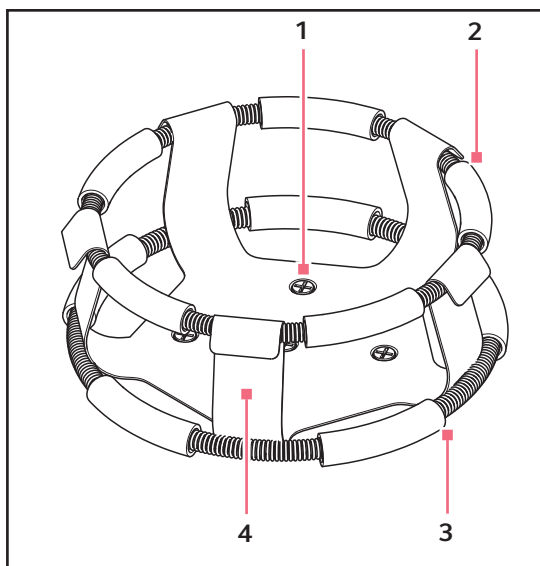

Fig. 4-2: Double Girdle Clamp Installation

- |   |  |
|---|--|
| <p><b>1 Clamp Mounting Holes (5)(with screws)</b></p> <p><b>2 Upper Girdle with Girdle Tubes</b><br/>Secures the flask within the clamp</p> | <p><b>3 Lower Girdle with Girdle Tubes</b><br/>Prevents the flask from spinning</p> <p><b>4 Clamp body (legs and base)</b></p> |
|---|--|



Fig. 4-3: Clamp Fastener

**i** The upper girdle secures the flask within the clamp, and the bottom girdle keeps the flask from spinning.

New Brunswick flask clamps are used on a variety of shaker platforms. Flat head screws of different lengths and thread pitch are used to secure the clamp. The following table identifies the proper screw for your shaker application by reference to the head style. Select the appropriate screws and set the others aside.

Tab. 4-1: Clamp Hardware Application Chart

Description	Part Number	Quantity	Application
10 – 24 x 5/16 in (7.9 mm) flat Phillips (+) head screw	S2116-3051	1	7.9 mm (5/16 in) thick aluminum, phenolic and stainless steel platforms.

No matter what size the clamp is, use these screws above to fasten them to your platform.

**i** 1 L and larger flask clamps are fastened with 5 screws.

#### 4.11 Electrical connections

Before making electrical connections, be sure to check the following:

1. If you have not already done so, check that the voltage and frequency of your unit are compatible with your electric supply.
2. Remove the caution label from the rear of the unit.
3. Set the circuit breaker on the right side of the unit to the OFF position.



**CAUTION! Personnel injury and equipment damage!**

▶ A grounded electrical outlet is necessary for the safe operation of this instrument.

4. Only then, plug the power cord into a grounded electrical outlet.

#### 4.12 Optional culture drawer

If you plan to use the optional culture drawer, it would be a good idea to install it before stacking units. For installation instructions, (see *Optional culture drawer on p. 23*).

**Installation**

New Brunswick™ Innova® 42/42R Shaker  
English (EN)

### 4.13 Stacking instructions



**WARNING! Personnel injury and equipment damage!**

- ▶ Do not attempt to lift the Innova 42/42R by yourself. Always ask for assistance or use a lifter or other suitable equipment when raising or handling the unit.

#### 4.13.1 Stacking Kit

Innova 42 and 42R shakers can be stacked 2 high, to save floor space. If stacked, an Innova 42/42R Stacking Kit must be used to provide additional stabilization. This stacking kit is used only to stack 2 Innova 42 and/or 42R shakers.

**Stacking kit parts list:** In the table below, item numbers 1 – 13 are included in the stacking kit.

Item Number	Part Number	Description	Quantity
1	M1335-9210	Base Weldment	1
2	M1335-9325	Bracket	4
3	S1834-9328	Screw, Mach, Hex Cap, 2 in L, 1/2-13, STL, Zinc	8
4	W1231-3228	Washer 1/2 Lock Zinc	12
5	W1131-3228	Washer 1/2 Flat Zinc	12
6	P0160-5940	Foot, Leveling, 1/2-13, S.S.	4
7	P0280-2870	Cap, 1 1/2 in x 1 1/2 in, Polyethylene	4
8	P0280-3152	Tape, Foam Strips	4.17 feet
9	M1335-9322	Stacking Bracket	2
10	S2134-9240	Screw, Hex 1 1/2 in L1/2 - 1355	10
11	W3231-3220	Washer, Lock, 1/2	14
12	W2131-1170	Washer, Flat, 1/2	10
13	P0220-1112	Steel Handle	4
14	N/A	Back Feet of Shaker	2
15	N/A	Innova 42/42R Shaker	1

The figure below is an exploded view of the stacking kit parts. The callouts in the figure match the item numbers in the above table.

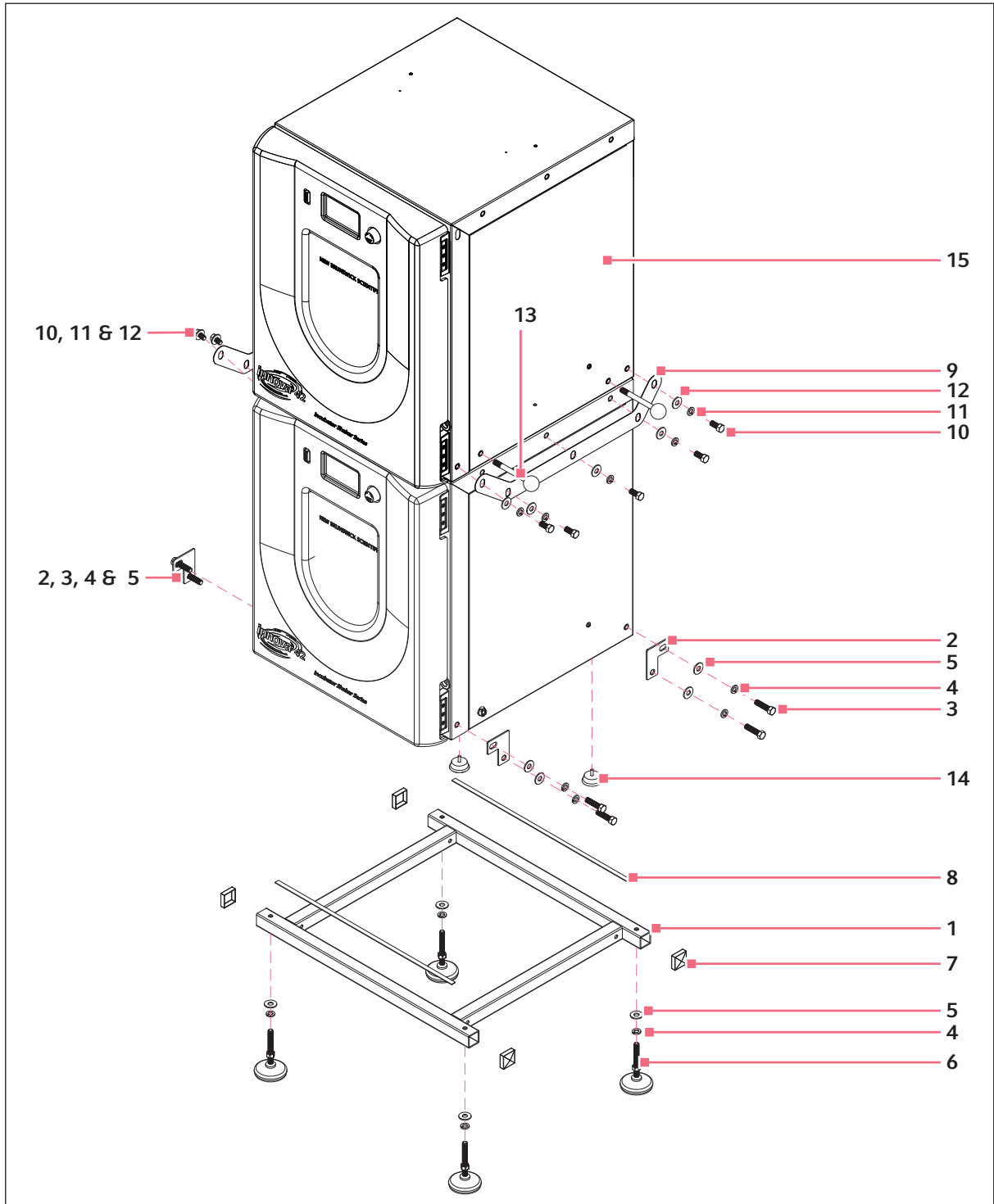

Fig. 4-4: Stacking Kit Parts (Exploded View)

## Installation

New Brunswick™ Innova® 42/42R Shaker  
English (EN)

### 4.13.2 For two Innova 42/42R shakers

To stack 2 Innova 42/42R shakers:

1. Determine which unit will be the bottom one. If you are stacking a 42 with a 42R, place the non-refrigerated 42 on top.



#### CAUTION! Equipment damage!

- ▶ Do not tip a refrigerated unit (42R) on its side as this may damage the compressor.

2. Tilt the bottom shaker forward. Remove the 2 rear shaker feet.

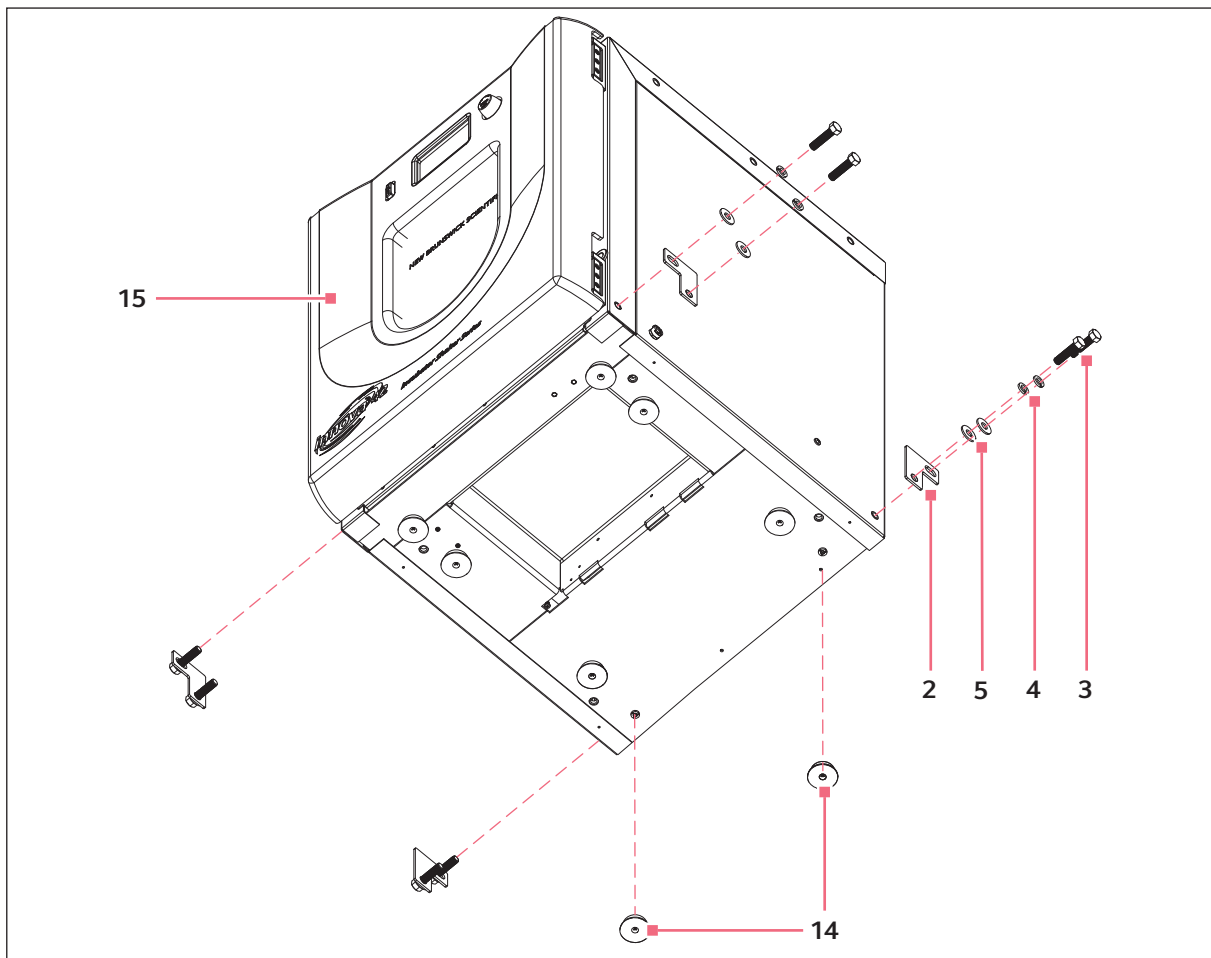

Fig. 4-5: Installing Brackets

2 Bracket

3 Screw

4 Lockwasher

5 Washer

14 Rear Feet

15 Innova 42/42R Shaker



3. Attach the bracket to the shaker, on all 4 sides, with the screws and washers as shown above.
4. Place the washers over the leveling feet as shown below.

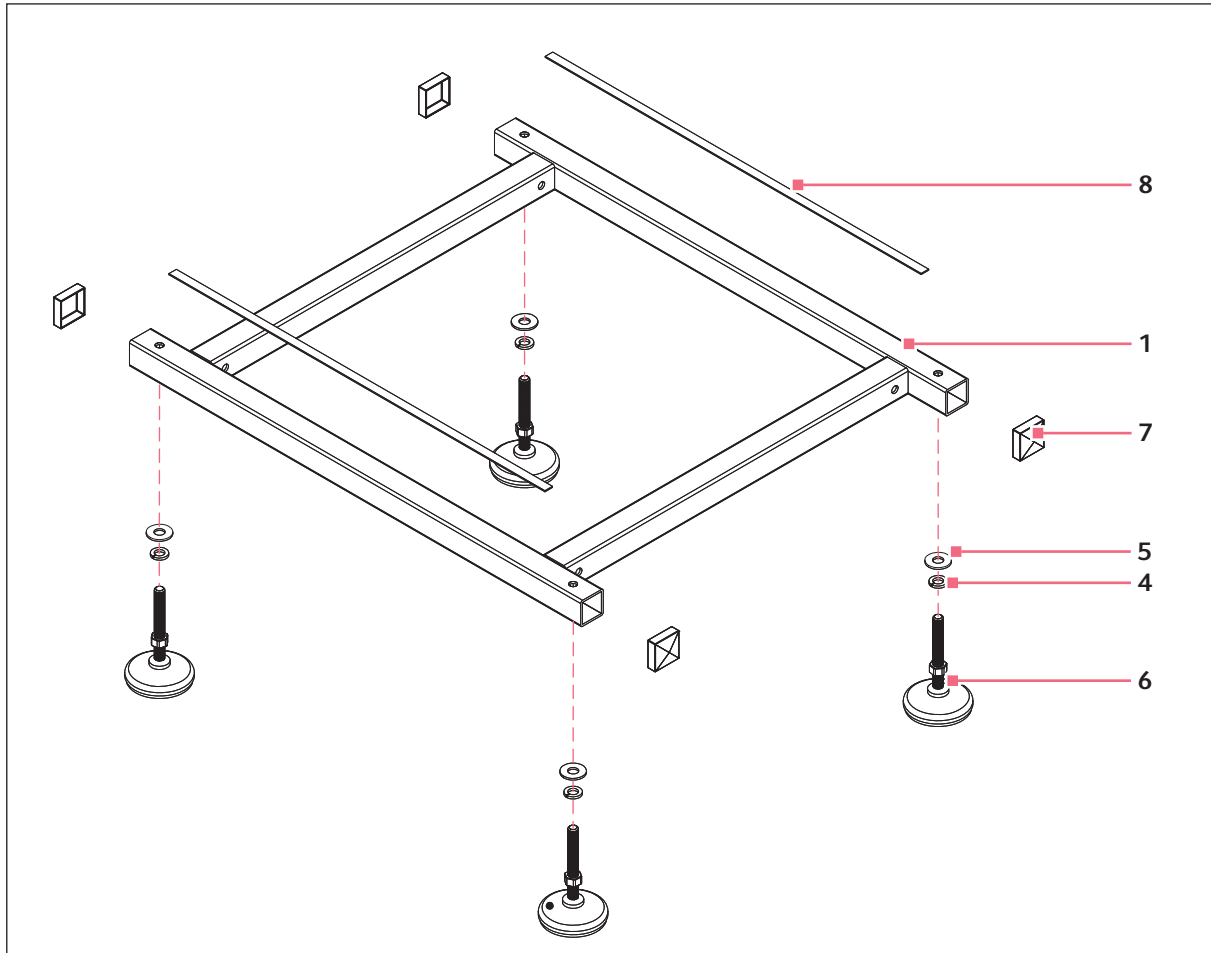

Fig. 4-6: Installing Leveling Feet

**1 Base Weldment**

**4 Lockwasher**

**5 Washer**

**6 Leveling Foot**

Leveling foot with locking nut.

**7 Cap**

**8 Foam strip Tape**

5. Level the base weldment by threading the leveling feet through the frame. Tighten the lock on the foot accordingly to level and lock each foot.
6. Cut the foam strip tape in half to make 2 strips and attach the strips to the front and back edges of the base weldment.
7. Attach the 4 caps to the base weldment.
8. Remove the plastic plugs from the mounting holes on both shakers' side panels. There are 2 per side at the bottom of the top shaker and at the top of the bottom shaker.

**Installation**

New Brunswick™ Innova® 42/42R Shaker  
English (EN)

9. Insert the 4 steel lifting handles (#13) into the shaker.

**WARNING! Personnel injury and equipment damage!**

- ▶ Do not attempt to lift the Innova 42/42R by yourself. Always ask for assistance or use a lifter or other suitable equipment when raising or handling the unit.

10. Mount the shaker on the base weldment. Use the handles to center the shaker. Attach the shaker to the base weldment with the brackets, screws, and washers as shown below.

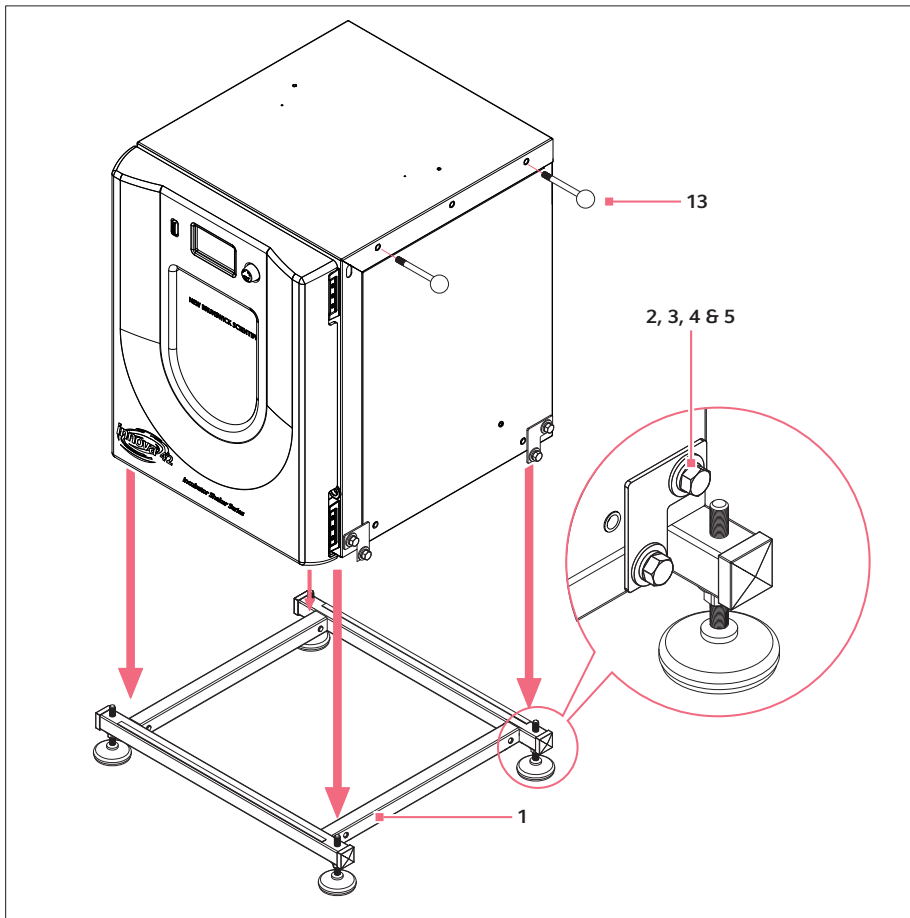

Fig. 4-7: Attaching Shaker to Base

**1 Base Weldment**

**2 Bracket**

**3 Screw**

**4 Lockwasher**

**5 Washer**

**13 Steel Lifting handle**

11. Insert the lifting handles into the previously plugged holes at the bottom of the shaker to be lifted.

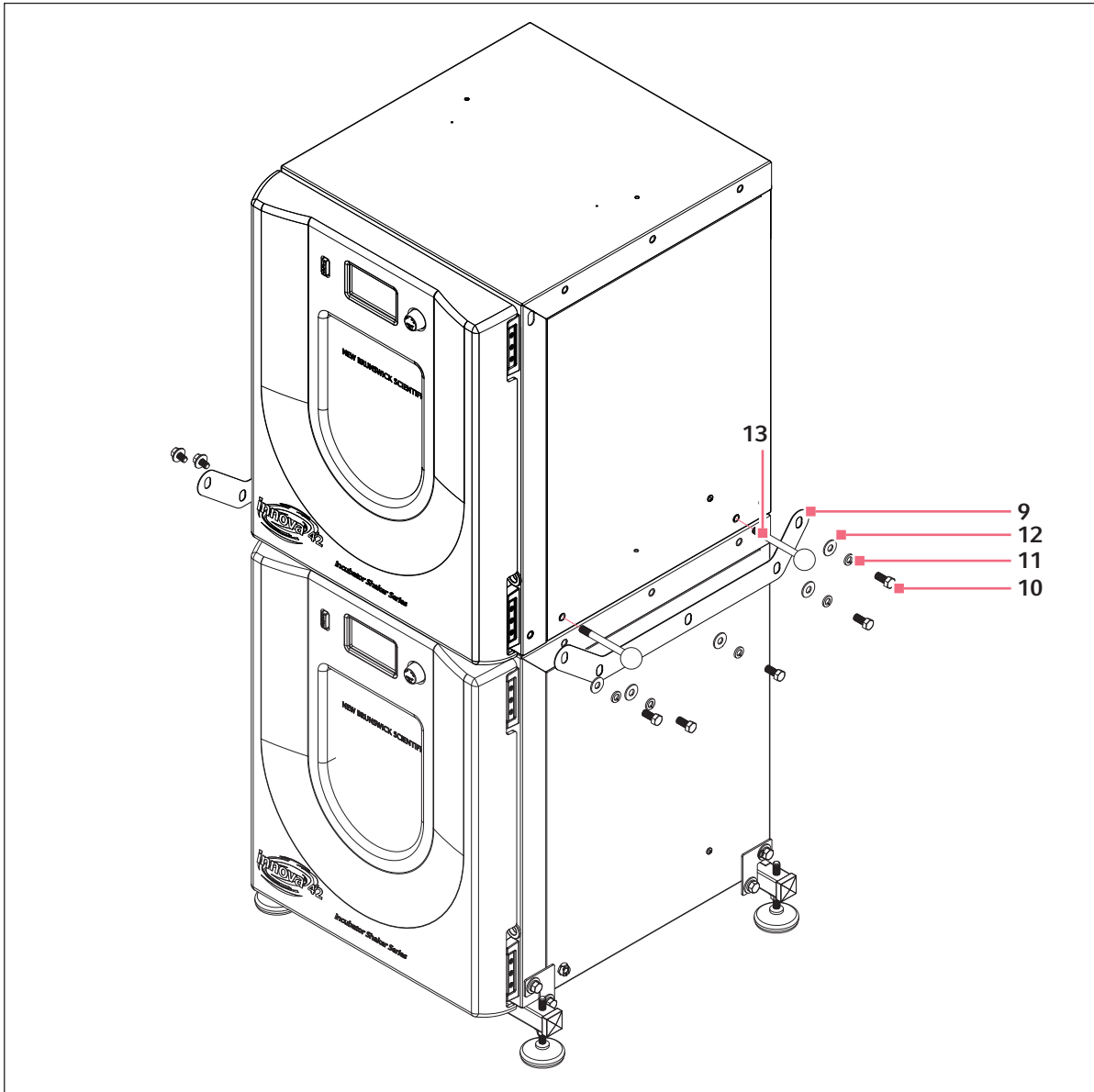

Fig. 4-8: Stacking 2 Innova 42/42R Shakers

**10 Stacking Bracket**

**11 Screw**

**12 Lockwasher**

**13 Washer**

**14 Steel Handle**

12. Use a lifting device to place 1 shaker on top of the other, both facing in the same direction as shown. Use the handles (#14) to position the units so they are squarely aligned on top of each other.

**Installation**

New Brunswick™ Innova® 42/42R Shaker  
English (EN)

13. Remove the handles and replace the plugs.
14. Align each side of the stacking bracket with the mounting holes on both shakers and, using the screws and washers, install both stacking brackets as shown above.
15. Check the units with a level again, adjusting the feet if needed. See the figure below for a completed view.

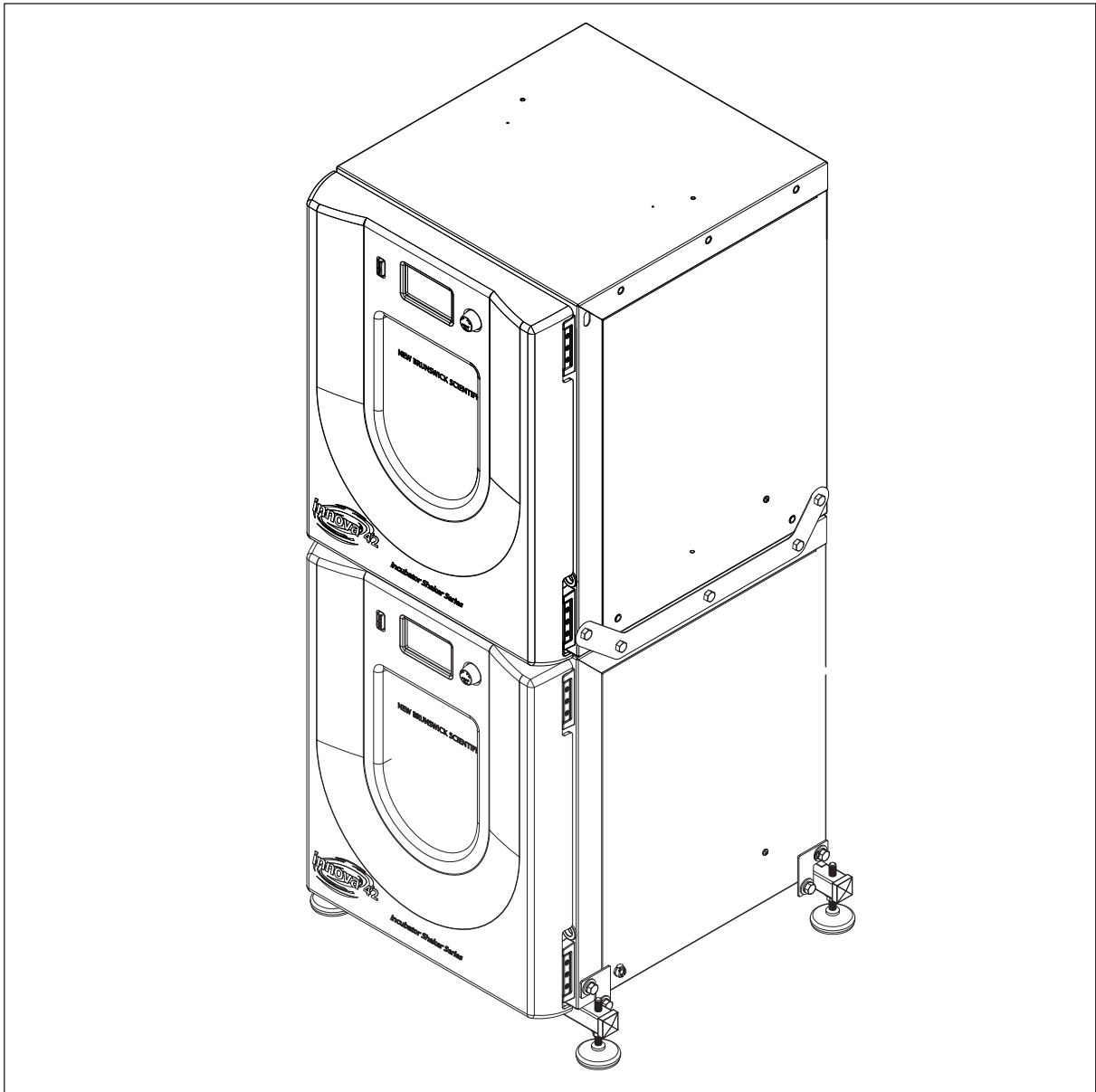

Fig. 4-9: Stacked View Completed

#### 4.13.3 For an Innova 4200/4230 on an Innova 42/42R

To stack an Innova 4200 or 4230 on an Innova 42 or 42R shaker:

1. Install four P0160-5941 stacking feet, each with its flat washer, on top of the locking nut in each of the 4 weld nuts on the underside of the bottom unit. You will need to tilt the cabinet back in order to install them.



**CAUTION! Equipment damage!**

- ▶ Do not tip a refrigerated unit (42R) on its side as this may damage the compressor.
- 



Be certain to make sure the unit is level so the units will operate properly.

2. Level the bottom unit and lock the feet in place with the locking nuts.
3. With the help of a lifter or other suitable equipment, place center the Innova 4200/4230 over the Innova 42/42R, both facing in the same direction as shown below (see Fig. 4-10 on p. 38).

**Installation**

New Brunswick™ Innova® 42/42R Shaker  
English (EN)

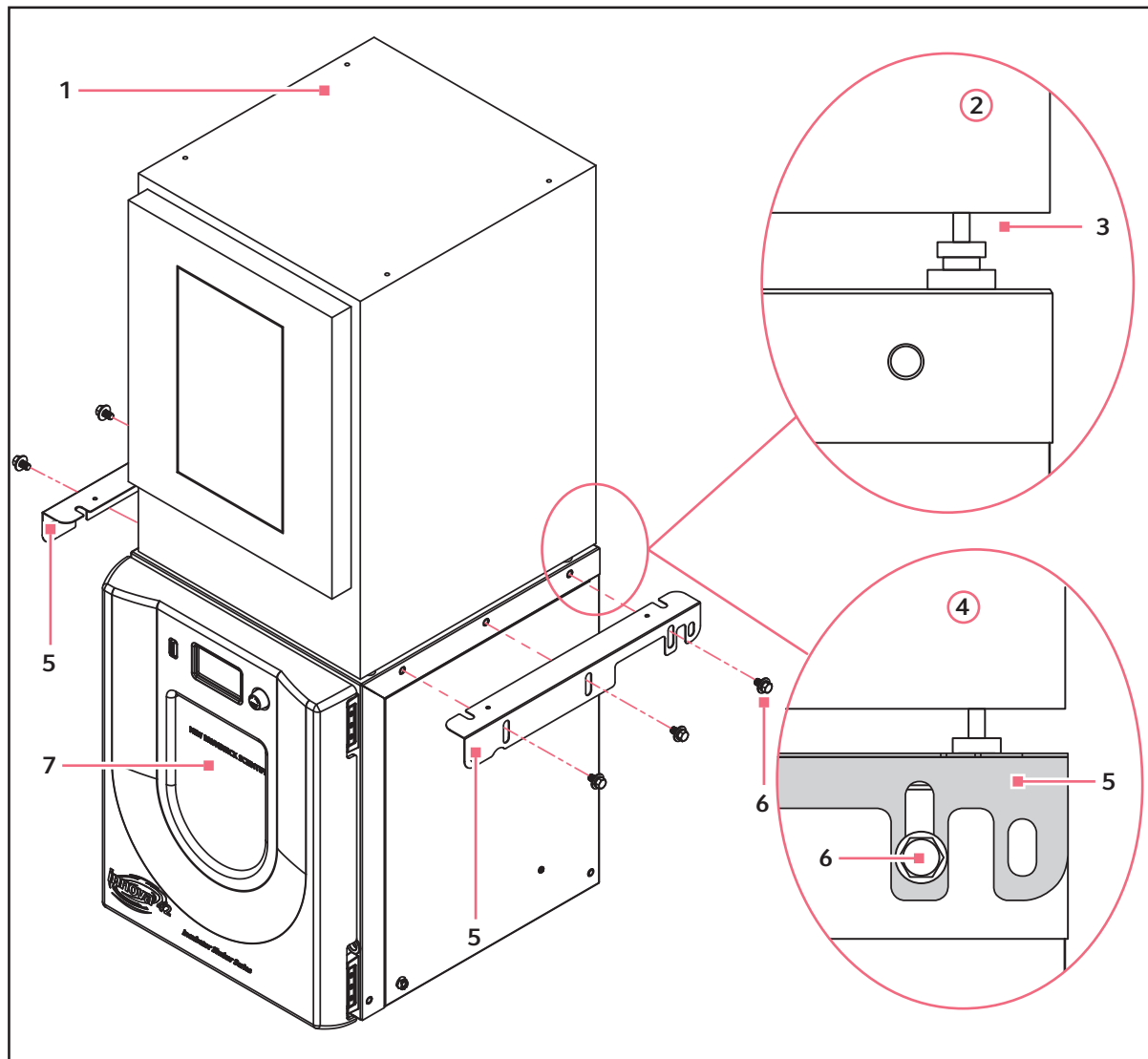

Fig. 4-10: Stacking an Innova 4200/4230 on an Innova 42/42R

- |  |                               |
|--|-------------------------------|
| 1 Innova 4200/4230                             | 5 Stacking Frames             |
| 2 Detail View Without Stacking Frame Installed | 6 Bolts, Washers and Locknuts |
| 3 Stacking foot                                | 7 Innova 42/42R               |
| 4 Detail View With Stacking Frame Installed    |                               |

4. Align each side of the stacking frame with the mounting holes on both shakers, also taking care to align the grooves with the Innova 4200/4230's feet, as shown above.
5. Fasten the stacking frames in place using the bolts, washers and locking nuts provided. The frame should rest over the top of the Innova 4200/4230's feet as shown.
6. Check the units with a level again, adjusting the feet if needed.

## 5 Operation

### 5.1 Platform assemblies

The Innova 42/42R can be used with a variety of Eppendorf platforms that will accept a wide range of clamps for flasks, test tubes, etc. A platform, which is required for operation, is a separate item, not included with the shaker assembly. For details on available platforms and platform accessories, (see *Platforms on p. 73*).

### 5.2 Installation of platform

Prior to use, a spill cover and platform must be installed on the unit. The shaker is shipped with 4 Allen head platform screws installed in the bearing housing (see Figure below, which also shows the spill cover that you must install). Set the power to OFF and unplug the unit. Remove the platform screws, then use them to install the spill cover (sometimes also referred to as a drip tray) and platform over the bearing housing:

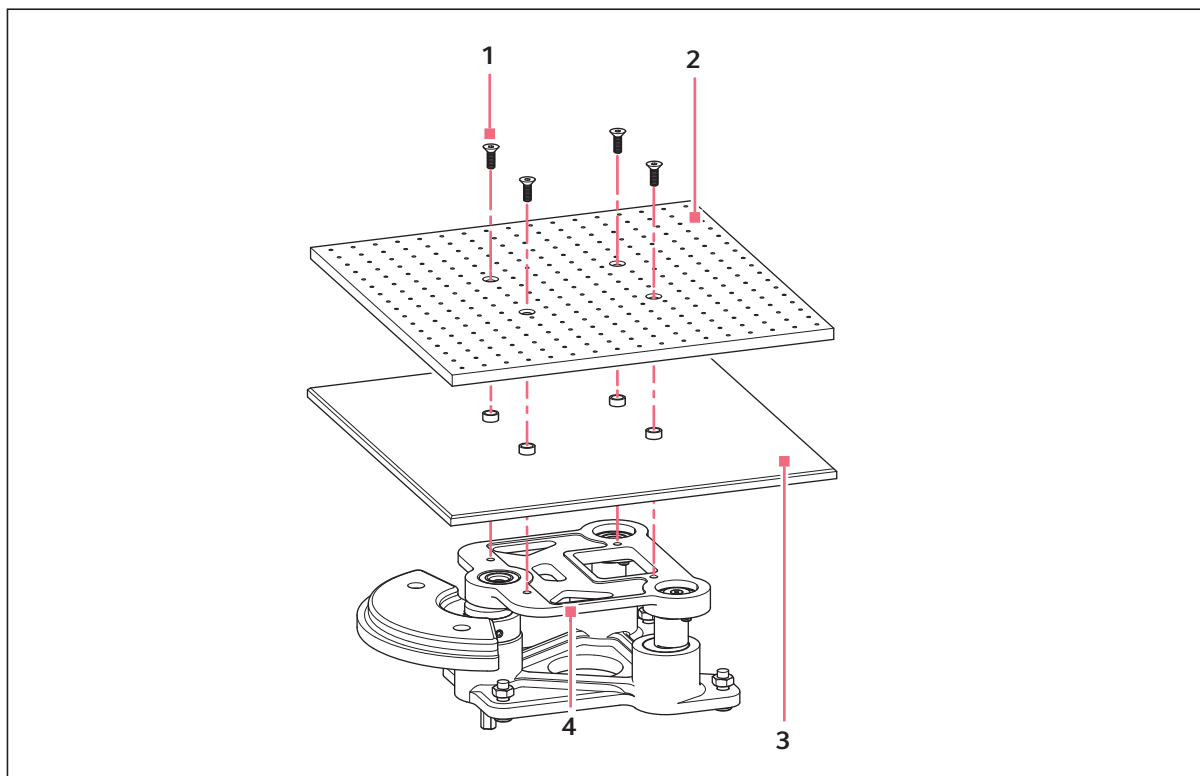

Fig. 5-1: Installing Platform and Spill Cover

1 Allen Head Platform Screws

3 Spill Cover

2 Platform

4 Bearing Housing

**Operation**

New Brunswick™ Innova® 42/42R Shaker  
English (EN)

### 5.3 Safety precautions

Before operating the shaker, verify that anyone involved with its operation has been instructed in both general safety practices for laboratories and specific safety practices for this apparatus.

The user is also responsible for following local guidelines for handling hazardous waste and biohazardous materials that may be generated from the use of this equipment.

If service should be required on a unit that is going to be returned to an Eppendorf facility, it must be completely decontaminated and cleaned prior to its return.

It is the responsibility of the user to carry out appropriate decontamination procedures if hazardous material is spilled on or inside the equipment. Before using any cleaning or decontamination method other than those suggested by the manufacturer, users should check with Eppendorf that the proposed method would not damage the equipment.

This equipment is not "explosion-proof" and should never be used with flammable substances or used to grow organisms that produce flammable by-products.

**CAUTION! Equipment damage!**

- ▶ To prevent damage to the shaker and its contents, never run the shaker without a platform.
- 

### 5.4 Fill the drip pan reservoir

If you choose to use the drip pan reservoir as a water reservoir to reduce evaporation and to raise the humidity level in the chamber:

1. Open the door and temporarily remove the platform.
2. Make sure that the drain check valve is closed.



As you add water, do not allow the water to splash or flow into the recessed middle of the pan, where the bearing housing assembly is mounted. Pour water very slowly into the shallow area beyond the edge of the spill cover to protect the bearing housing.

3. Accessing the pan/reservoir from the left, the right or in front of the spill cover, slowly fill the reservoir with no more than 2 L of distilled water. A long, narrow watering can or a flexible hose will make it easier to access the pan while protecting the bearing housing from accidental overflow.

At a 37 °C setpoint, the chamber loses approximately 50 mL/h from the pan.

At a 25 °C setpoint, and placed in a 25 °C room, the chamber achieves a relative humidity equilibrium that is approximately 15 % above the ambient humidity.



## 5.5 Drain the drip pan reservoir

To drain water from the drip pan reservoir:

1. Attach the quick-connect drain fitting, direct it to a container or drain, and allow the water to gravity drain.



The drip pan reservoir drain is located in the front, on the left, under the humidity tray.

2. When the reservoir is empty, detach the fitting.

## 5.6 Start the shaker

To initially start the shaker, close the door and turn the power switch to the ON (I) position. The display will come on (first showing only New Brunswick Scientific, then briefly displaying the model number, 42 or 42R, and the orbit, 3/4 in or 1 in, and then quickly moving into the Display screen), and the audible alarm will sound. If you turn the Control Knob, the audible alarm will stop. For details on muting and activating the alarm, (see *Mute the audible alarm on p. 56*).

When the shaker begins to operate, the LCD display will track the speed as it accelerates to the last entered setpoint. The shaking action may be started or stopped by pressing the Start/Stop button on the front panel.



The shaker will not operate if the door is open. This is indicated by the “door open” icon appearing in the bottom line of the display (see Fig. 3-4 on p. 17).

## 5.7 Using the LCD screens

### 5.7.1 Display screen

When you turn the power on, this is the first screen to appear after the company title screen. The default display parameters are temperature (°C) and shaking speed (rpm).

**Operation**

New Brunswick™ Innova® 42/42R Shaker  
English (EN)

You can change the displayed parameters. **To replace a parameter:**

1. Using the Control Knob, highlight the parameter that you wish to replace. For this example, we will replace **RPM** (see Fig. 5-2 on p. 42).

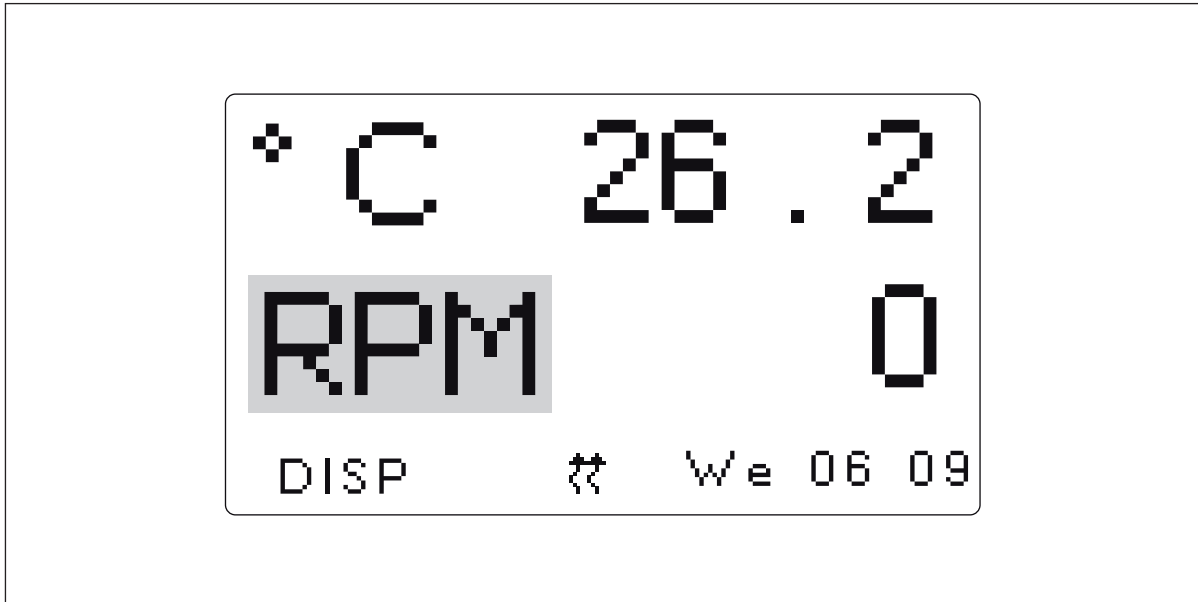

Fig. 5-2: Changing Display Parameter

2. Click the Control Knob in.  
**RPM** will flash.
3. Turn the Control Knob until the desired parameter appears in the highlighted field. For this example, we will select **HRS**.
4. Click the Control Knob in, to set and save the parameter (see Fig. 5-3 on p. 43).

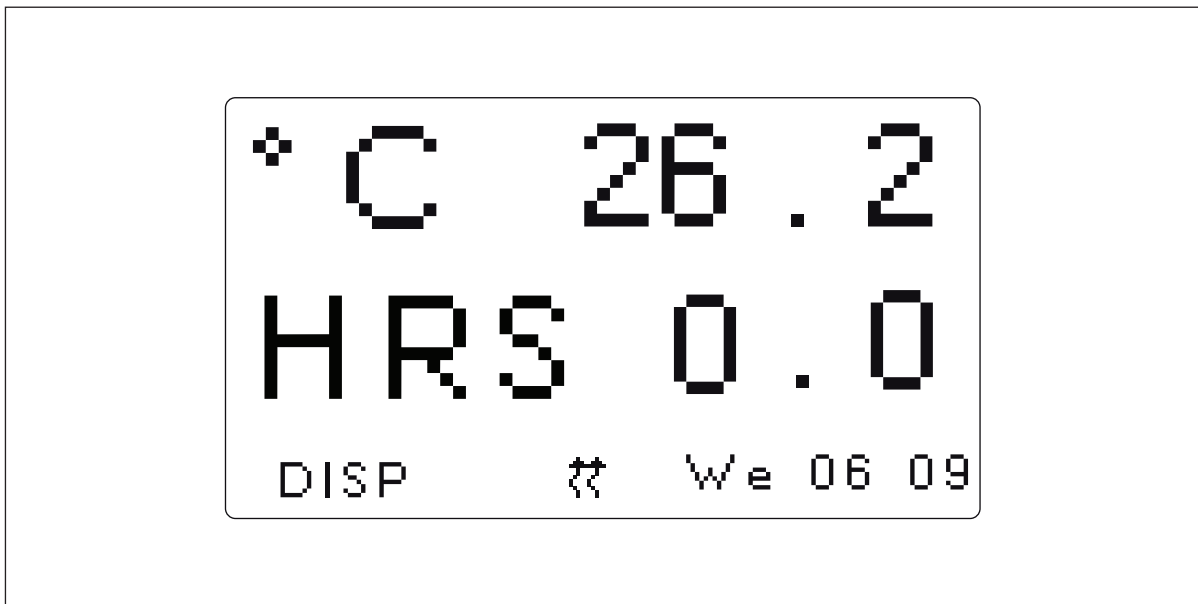

Fig. 5-3: Changed Display Parameter



If you highlight an item, change it, but do not save your selection, after a few seconds the screen will revert to its previous setting.

You can also use this screen to verify a setpoint, even though the values displayed here are actual (current) values.

**To view a setpoint:**

1. Use the Control Knob to highlight the value (in this example, we will view the temperature setpoint, so we will highlight the current °C, which is **26.2**).
2. Click the Control Knob in to display the current setpoint, which will flash.

At this point you can modify the setpoint or click the Control Knob in again to return to the normal display, which will be the actual temperature.

**To modify a setpoint in this screen:**

1. Use the Control Knob to highlight the current value (we will continue to use the temperature as our example, so we will select **26.2**).
2. Click the Control Knob in to display the current setpoint (in this example, **20.2**) (see Fig. 5-4 on p. 44), which will flash.

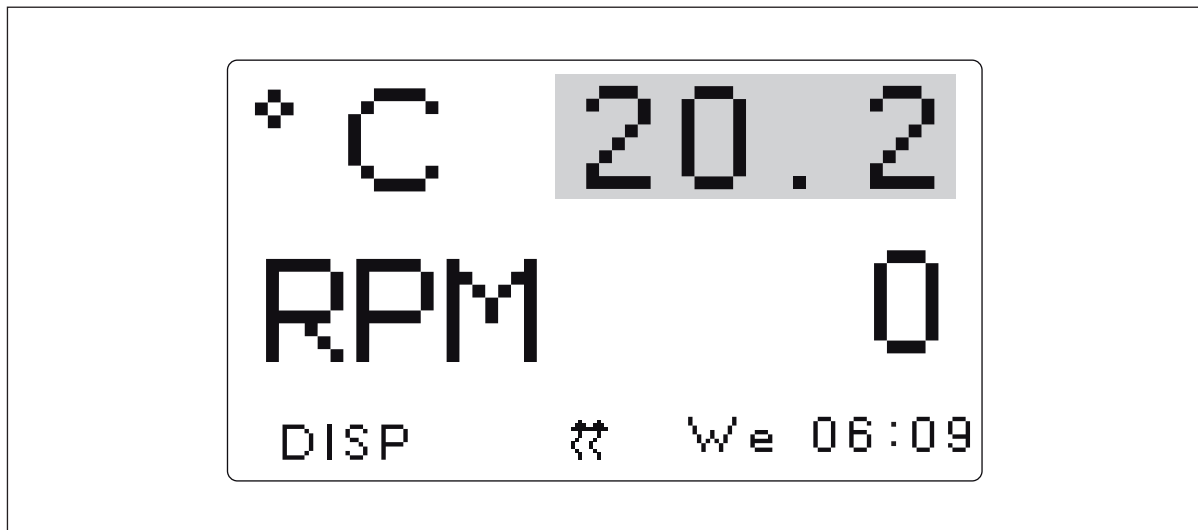

Fig. 5-4: Changing Setpoint

3. Turn or spin the Control Knob to reset the setpoint (in this example, turn the Control Knob right to increase the setpoint to **37.0**).



If you turn the Control Knob slowly, 1 click left or right will change the setpoint by an increment of 1 tenth of a degree Celsius (0.1 °C). If you spin the Control Knob, the value will change by larger increments.

4. Click the Control Knob in to set and save this new setpoint.



If you highlight an item, change it, but do not save your selection, after a few seconds the screen will revert to its previous setting.

5. The display will automatically return to the actual value.

#### To move out of this screen and into the next:

1. Use the Control Knob to highlight **DISP**, then click the Control Knob in.  
**DISP** begins to flash.
2. Turn the Control Knob to the right until the next screen, Summary (**SUMM**), appears. If you turn too far and enter another screen, just turn the Control Knob back to the left to recapture the **SUMM** screen.
3. Click the Control Knob in to select the screen and to work in it.

#### 5.7.2 Summary screen

In this screen (see Fig. 5-5 on p. 45), you can see both the current ACTUAL readings and the SETpoints for shaking speed (**RPM**), chamber temperature (**°C**), and elapsed time in a programmed run (**HRS**).

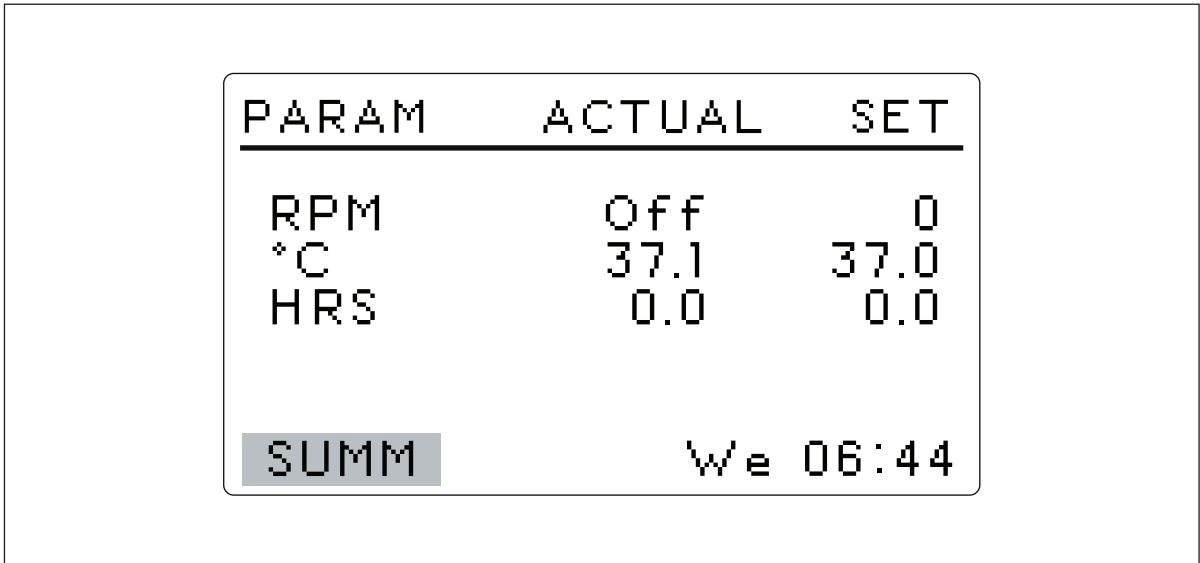



Fig. 5-5: Summary Screen

 The current day (Su, Mo, Tu, We, Th, Fr or Sa) and time always remains visible in the lower righthand corner.

The only elements you can modify in this screen are setpoints. **To change setpoints in this screen:**

1. Turn the Control Knob until the desired setpoint is highlighted, then click the Control Knob in. The setpoint will begin to flash.
2. Turn the Control Knob to the right to increase the number, or to the left to decrease it. One click left or right will increase the setpoint by an increment of 1 (1 whole unit or 1 tenth unit, depending on the parameter). Move the Control Knob more rapidly (you can spin it) to change the value by larger increments.
3. Click the Control Knob in to set and save the new value.

 If you highlight an item, change it, but do not save your selection, after a few seconds the screen will revert to its previous setting.

4. Repeat the above steps to change any or all of the other setpoints.

**To move out of this screen and into the next:**

1. Use the Control Knob to highlight **SUMM**, then click the Control Knob in. **SUMM** begins to flash.
2. Turn the Control Knob to the right until the next screen, Setup (**SET**), appears. If you turn too far and enter another screen, just turn the Control Knob back to the left to recapture the **SET** screen.
3. Click the Control Knob in to select the screen and to work in it.

**Operation**

New Brunswick™ Innova® 42/42R Shaker  
English (EN)

### 5.7.3 Setup screen

Here you can set the day of the week and the time (on a 24-hour clock). This screen also allows you to lock all of your settings from further changes, and to mute or enable the audible alarm.

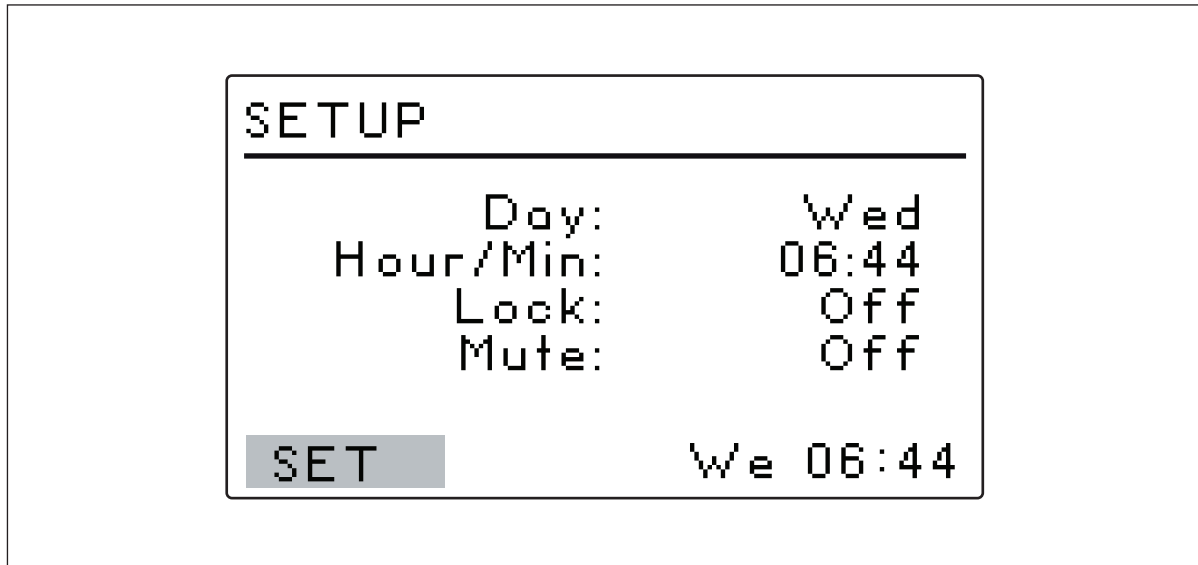

Fig. 5-6: Setup Screen

#### To change the day:

1. Turn the Control Knob to highlight the day (Thu in the sample screen above), then click inward once. The day will flash.
2. Turn the Control Knob left or right to select the day of choice: Sun, Mon, Tue, Wed, Thu, Fri or Sat.
3. Click the Control Knob in to set and save your choice.



If you highlight an item, change it, but do not save your selection, after a few seconds the screen will revert to its previous setting.

#### To change the time (Hour/Min):

1. Turn the Control Knob to highlight the time (**16:19** in the sample screen above), then click inward once. The time will flash.
2. Turn the Control Knob left or right to change the time. Left moves backward, right moves forward in time. One click right or left changes by 1 min; spin the Control Knob to move more rapidly.
3. Click the Control Knob once inward to set and save your choice.

#### To lock the settings:

1. Turn the Control Knob to highlight **Lock**, then click inward once. The current status (**Off** in the sample screen above) will flash.

2. Turn the Control Knob in either direction; the only other choice is **On**. Click once inward to select and save **On**, or continue turning to return to **Off**.
3. When you set **Lock** to **On**, the lock icon will appear at the bottom of the screen. This icon will remain on display through all main display screens until you turn the locking function off.

**To mute the audible alarm:**

1. Turn the Control Knob to highlight **Mute**, then click inward once.  
The current status (**Off** in the sample screen above) will flash.
2. Turn the Control Knob in either direction; the only other choice is **On**. Click once inward to select and save **On**, or continue turning to return to **Off**.
3. When you set **Mute** to **On**, the crossed out speaker icon will appear at the bottom of the screen. This icon will remain on display through all screens until you turn the muting function off.

**To move out of this screen and into the next:**

1. Use the Control Knob to highlight **SET**, then click the Control Knob in.  
**SET** begins to flash.
2. Turn the Control Knob to the right until the next screen, RS-232 (**RS232**), appears. If you turn too far and enter another screen, just turn the Control Knob back to the left to recapture the **RS232** screen.
3. Click the Control Knob in to select the screen and to work in it.

#### 5.7.4 Lamps screen

In this screen (see Fig. 5-7 on p. 48), you can turn the chamber lamp (**Chamber**), the optional UV germicidal (“decontamination”) lamp (**UV Decont**) and the optional photosynthetic growth lamps (**Growth**) on and off.

**On** means the lamp is always on, and **Off** means the lamp is always off, unless you add additional programming.

There is an additional mode for the chamber lamp: **Auto**. In **Auto** mode, the lamp will go on every time you activate the Control Knob or open the door. This is the default mode.



The Lamps screen, shown below, will always indicate Chamber lamp mode. If the shaker is not equipped with the optional UV germicidal lamp and/or photosynthetic growth lamps, UV Decont and/or Growth will say None.

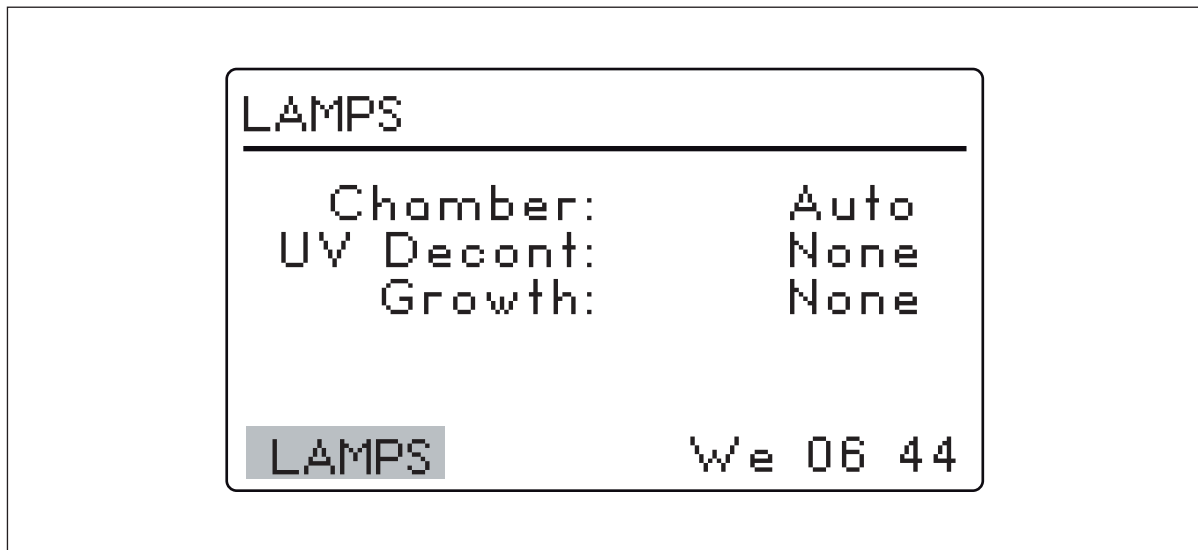

Fig. 5-7: Lamps Screen

**To change the mode setting for any of the lamps:**

1. Turn the Control Knob to highlight the setting for the lamp of choice, then click the Control Knob in. The current setting will flash (in the sample screen, we will use the Chamber lamp as an example).
2. Turn the Control Knob left or right until the desired mode setting appears (**Auto** in this example).
3. Click the Control Knob in to save the new setting.



If you highlight an item, change it, but do not save your selection, after a few seconds the screen will revert to its previous setting.

**To move out of this screen and into the next:**

1. Use the Control Knob to highlight **LAMP**, then click the Control Knob in. **LAMP** begins to flash.
2. Turn the Control Knob to the right until the next screen, RS232 (**COMM**), appears. If you turn too far and enter another screen, just turn the Control Knob back to the left to recapture the **COMM** screen.
3. Click the Control Knob in to select the screen and to work in it.

## 5.7.5 RS232 screen

This screen (see Fig. 5-8 on p. 49) is used only if you have connected a personal computer to the RS-232 port (see *Software interfaces on p. 20*). Here you can select the RS-232 port's **Mode** and the **Baud Rate** appropriate to your PC.



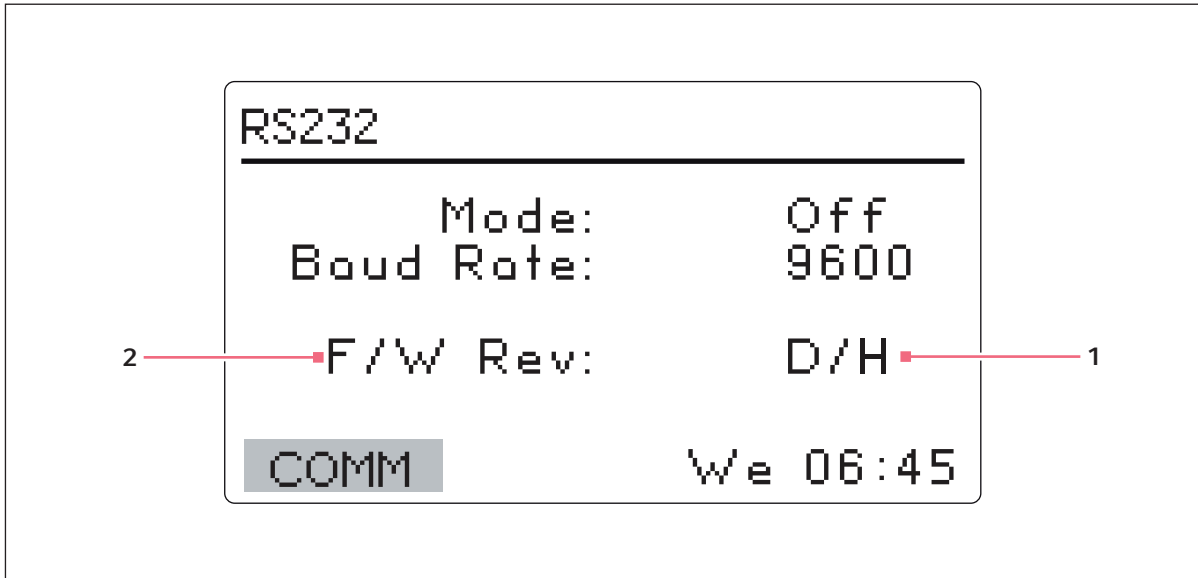

Fig. 5-8: RS232 Screen

- 1** In this sample screen, the Display is at Revision 2 and the Firmware Control Board at Revision H.  
**2** Firmware Revision level (this line is for information only)

**To change the Communication Mode:**

1. Turn the Control Knob to highlight the current setting (**Off** in the sample screen above), then click the Control Knob in.  
 The current setting will flash.
2. Turn the Control Knob left or right until the desired mode setting appears (see Table below):
3. Click the Control Knob inward once to save the new setting.

**i** If you highlight an item, change it, but do not save your selection, after a few seconds the screen will revert to its previous setting.

Mode	Application
Off	The RS-232 port is not open to communication in either direction.
Slave	The shaker can be fully controlled from the computer.
Talk	The shaker sends current value reports to the computer once per minute.
Monit (Monitor)	The shaker responds only to "Report Requests".

**Operation**

New Brunswick™ Innova® 42/42R Shaker  
English (EN)

**To change the Baud Rate:**

1. Turn the Control Knob to highlight the current setting (**19200** in the sample screen above), then click the Control Knob inward once.  
The current setting will flash.
2. Turn the Control Knob left or right until the desired setting appears: **9600**, **19200** or **38400**. The setting you choose should match the baud rate of your computer.
3. Click the Control Knob inward once to save the new setting.

**To move out of this screen and into the next:**

1. Use the Control Knob to highlight **COMM**, then click the Control Knob in.  
**COMM** begins to flash.
2. Turn the Control Knob to the right until the next screen, Calibrate (**CAL**), appears. If you turn too far and enter another screen, just turn the Control Knob back to the left to recapture the **CAL** screen.
3. Click the Control Knob in to select the screen and to work in it.

**5.7.6 Calibrate screen**

Use this screen (see Fig. 5-9 on p. 50) to create a temperature offset and to calibrate the shaking speed (for details, (see *Temperature offset calibration on p. 57*) and (see *Using Calspeed on p. 58*).

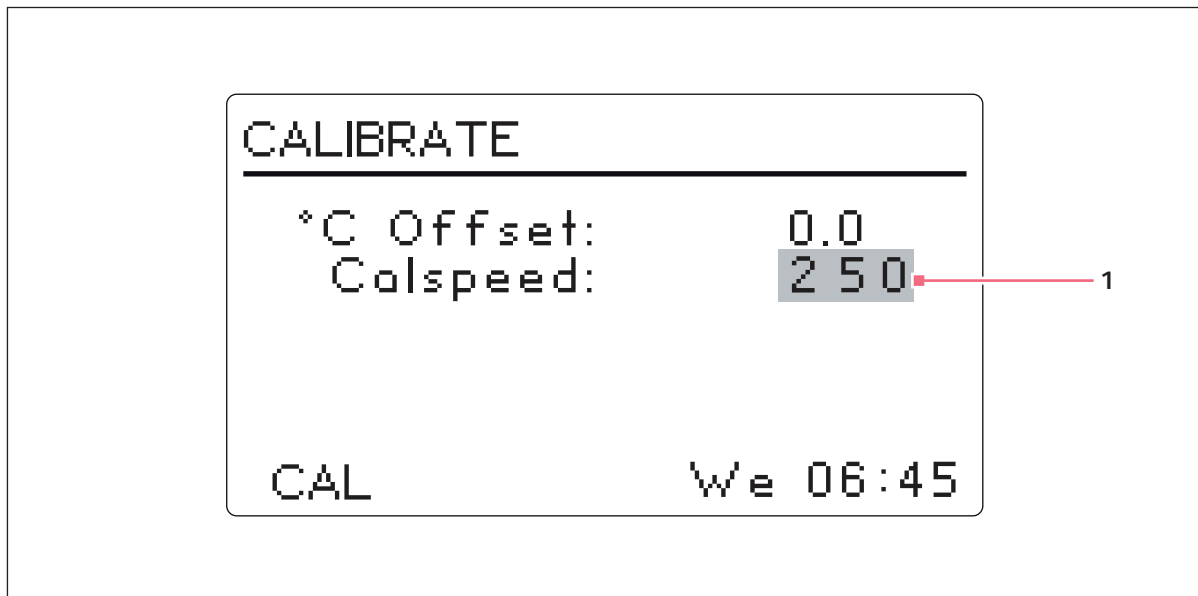

Fig. 5-9: Calibrate Screen

- 1 This is a sample of the indicated RPM value.

### 5.7.7 Programs screen

Use this screen (see Fig. 5-10 on p. 51) to set as many as 4 operating programs for the shaker. Each program can have as many as 15 steps. For complete details, (see *Programming the shaker on p. 51*).

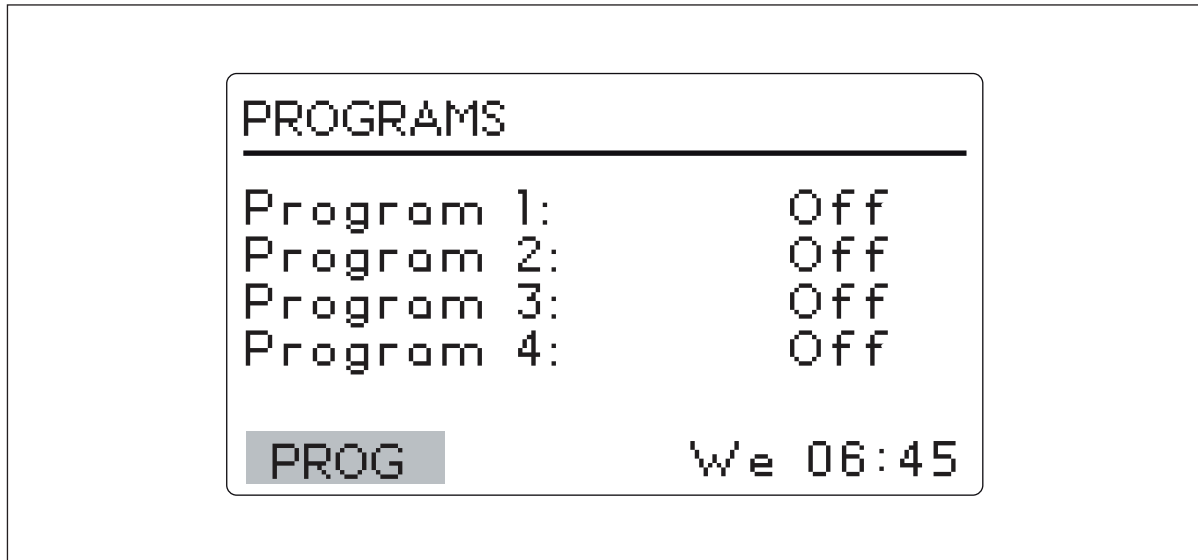

Fig. 5-10: Programs Screen

## 5.8 Programming the shaker

### 5.8.1 Timer only

By setting an **HRS** setpoint in the **DISP** or **SUMM** screen, the shaker may be set to automatically stop after a preset time period of 0.1 h – 99.9 h.

If the time is set to 0.0, the shaker will operate continuously until either the door is opened or the Start/Stop button is pushed.

### 5.8.2 Programmed steps

The resident software for the Innova 42/42R can store up to 4 programs, each having as many as 15 steps. Each step can be programmed in 1 min increments, for total periods of 1 min up to 99 h 59 min each.

To enter the programming mode, use the Control Knob to select the **PROG** screen (see Fig. 5-11 on p. 52). At this point, you can **Run** a program, **Edit** a program, generate a **New** program or turn a program **Off**. **Off** is the default mode.

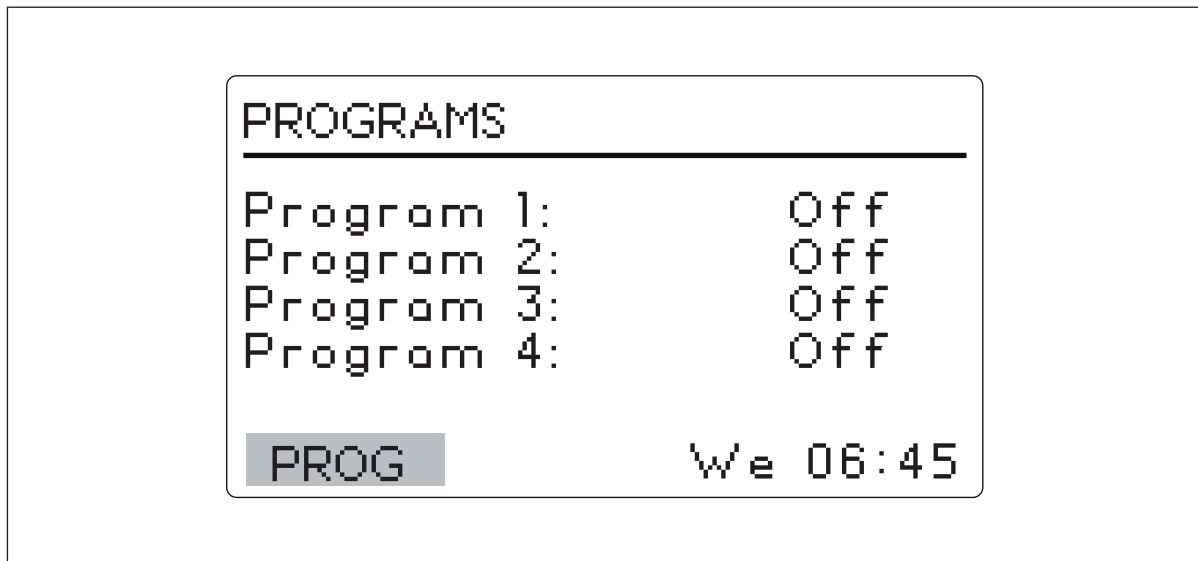

Fig. 5-11: Programs Screen

### 5.8.3 Create a program

#### To write a New program:

1. Use the Control Knob to highlight the mode of Program 1 (in our sample screen, it is **Off**), then click the Control Knob in.

The selected field begins to flash.

- Turn the Control Knob until the field says **New**. Click the Control Knob in to select this mode. The screen for Program 1 - Step 1 will open (see Fig. 5-12 on p. 53):

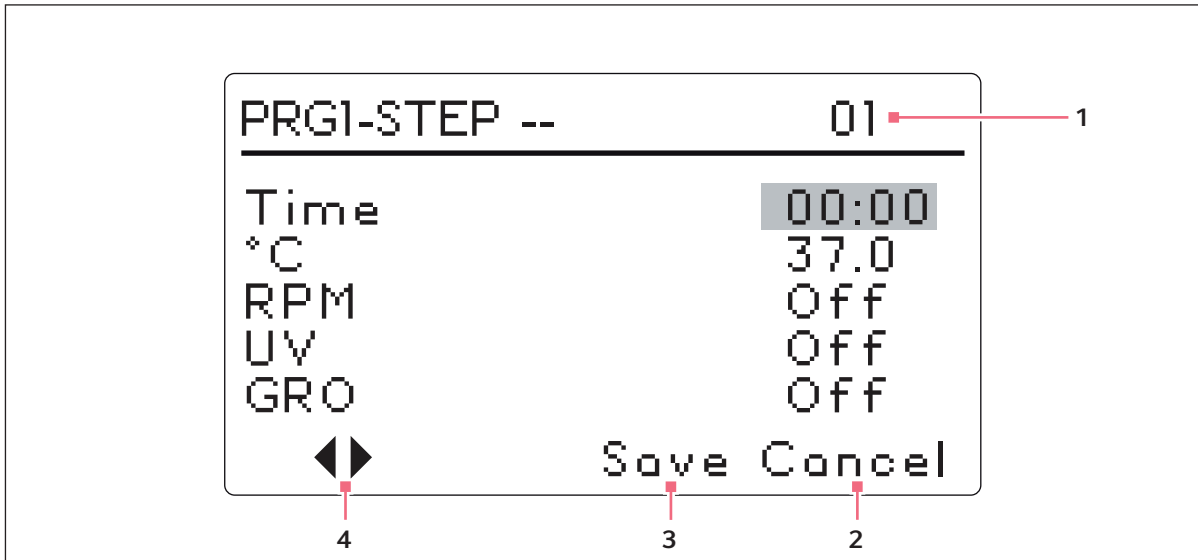

Fig. 5-12: Program 1, Step 1

- |   |  |
|---|--|
| <ol style="list-style-type: none"> <li><b>Step Number</b></li> <li><b>Use to leave programming mode without saving any new settings.</b></li> </ol> | <ol style="list-style-type: none"> <li><b>Do not use until programming is complete.</b></li> <li><b>Use these arrows to scroll through steps.</b></li> </ol> |
|---|--|



If your shaker is not equipped with these optional features, "UV" and "GRO" will appear with the word "Off" in this screen but will not be programmable.

- Turn the Control Knob to highlight the Time setting (**00:00** in the sample screen above), then click the Control Knob in.  
The field will flash.
- Turn the Control Knob until the desired running duration for this step (from 00:01, which means 1 min, to 99:59) appears, then click the Control Knob in to save the setting. We will set Step 1 time to 8 h for this example (see Figure 17).
- Turn the Control Knob to highlight the °C temperature setting (**20.0** in the sample screen above), then click the Control Knob in.  
The field will flash.
- To set the temperature desired (°C from 4.0 to 80.0) for the time period you have set, turn the Control Knob (left to decrease, right to increase). When the desired value appears, click the Control Knob in to save the setting. We will set Step 1 temperature to **37.0 °C** (see Fig. 5-13 on p. 54).
- Turn the Control Knob to highlight the **RPM** setting (**Off** in the sample screen above), then click the Control Knob in.  
The field will flash.

**Operation**

New Brunswick™ Innova® 42/42R Shaker  
English (EN)

8. Turn the Control Knob to select the desired shaking speed (25 rpm – 400 rpm) for this time period, then click the Control Knob in to save the setting. We will set Step 1 speed to 150 rpm (see Fig. 5-13 on p. 54).

**i** DO NOT select “Save” yet!

9. To program Step 2 (see Fig. 5-13 on p. 54): use the Control Knob to highlight the arrows at the bottom left of the screen. Click the Control Knob to make the arrows flash, then turn the Control Knob to the right until Step 2 appears. Click the Control Knob in to work in this screen, and repeat Steps 3-10.

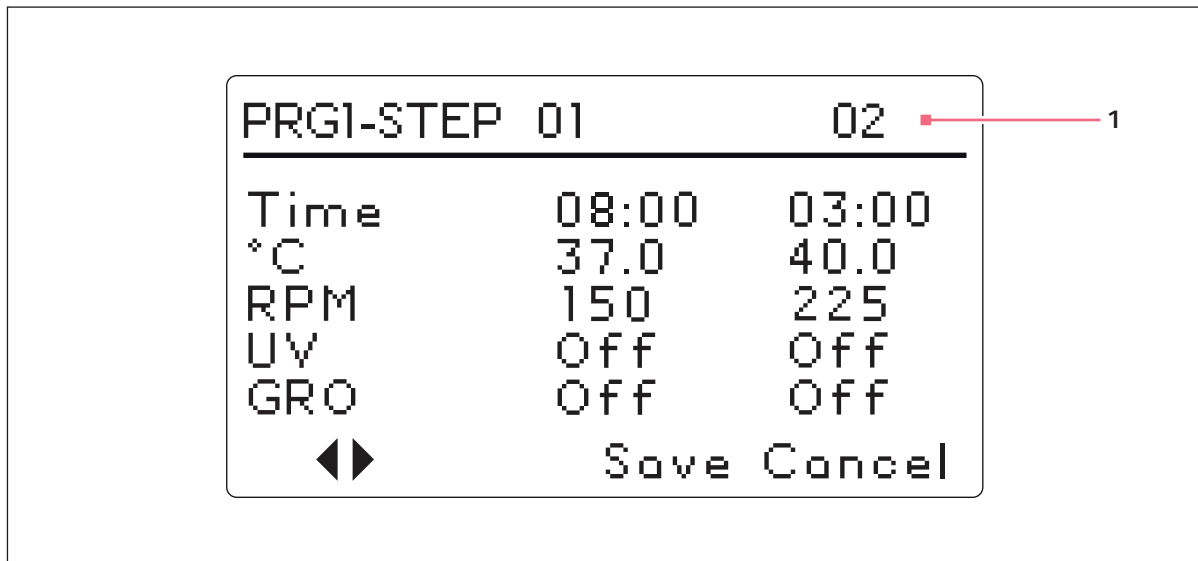

Fig. 5-13: Program 1, Step 2

### 1 Step Number

**i** Whatever step is shown on the right-hand side of the display is settable (in Figure above, it is Step 2). To scroll between steps, select the arrows (bottom left), then turn the Control Knob clockwise or counterclockwise, then select the desired step.

**i** The time entered for each step is for that step only; it is not cumulative (i.e., the elapsed time from the start of the program).

10. Continue to program as many as 15 steps in the same manner. For our sample program, we have only 3 steps (see Fig. 5-14 on p. 55).

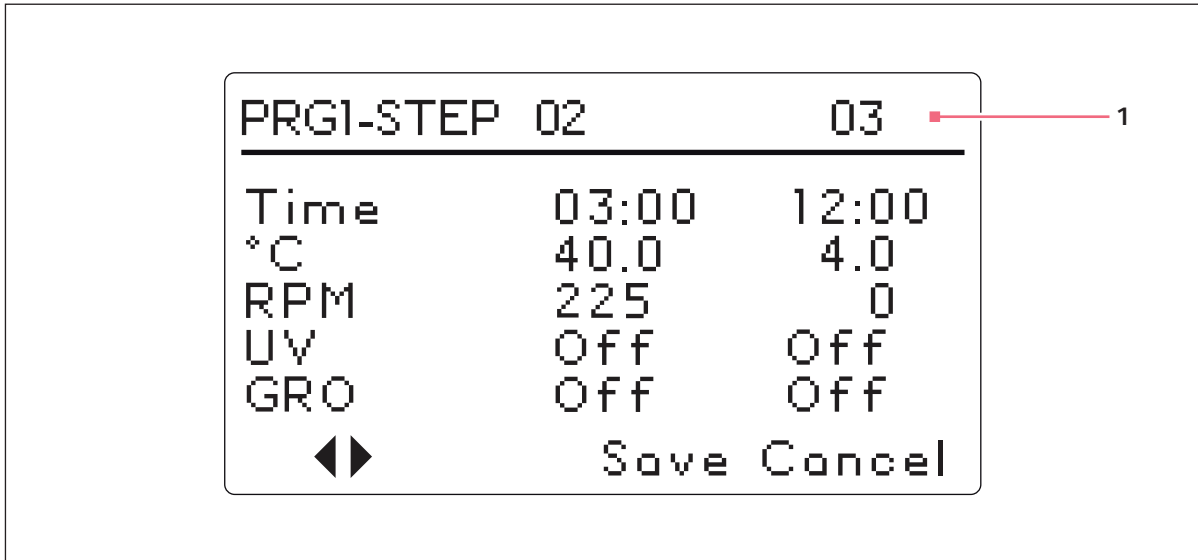

Fig. 5-14: Program 1, Step 3

### 1 Step Number

The 3-step program we have illustrated is designed to start incubating cultures at 37 °C and hold that temperature for 8 h, shaking at 150 rpm. After 8 h, Step 2 engages, increasing the temperature setpoint to 40 °C for a temperature induction, holding that temperature for 3 h and increasing the shaking speed to 225 rpm. After this interval, the temperature will be cooled to 4 °C and held at that temperature for 12 h; no shaking will occur during this period, as the speed is set to 0 rpm.

Please note that temperature reductions, even at temperatures above ambient (going from 40 °C to 30 °C, for example), require refrigeration to be effective.

#### To save the entire program:

- Once all your steps are set, use the Control Knob to highlight **Save** at the bottom of the screen, then click the Control Knob in.  
The field will flash.
- Click the Control Knob in again to save the program. The display will read **Process Running – Saving Profile** for a few seconds, then return to the main Programs (**PROG**) screen.

If you wish, you can set Programs 2, 3 and 4 and save them in the same manner.

### 5.8.4 Edit a program

Use the **Edit** function to open a program you have already created and saved, in order to modify your settings following the same procedures.

**Operation**

New Brunswick™ Innova® 42/42R Shaker  
English (EN)

### 5.8.5 Run a program

Use the **Run** function to turn a specific program on. Naturally, only 1 program can run at a time. When you change the mode to **Run**, the screen will show the Run icon (see Fig. 5-15 on p. 56):

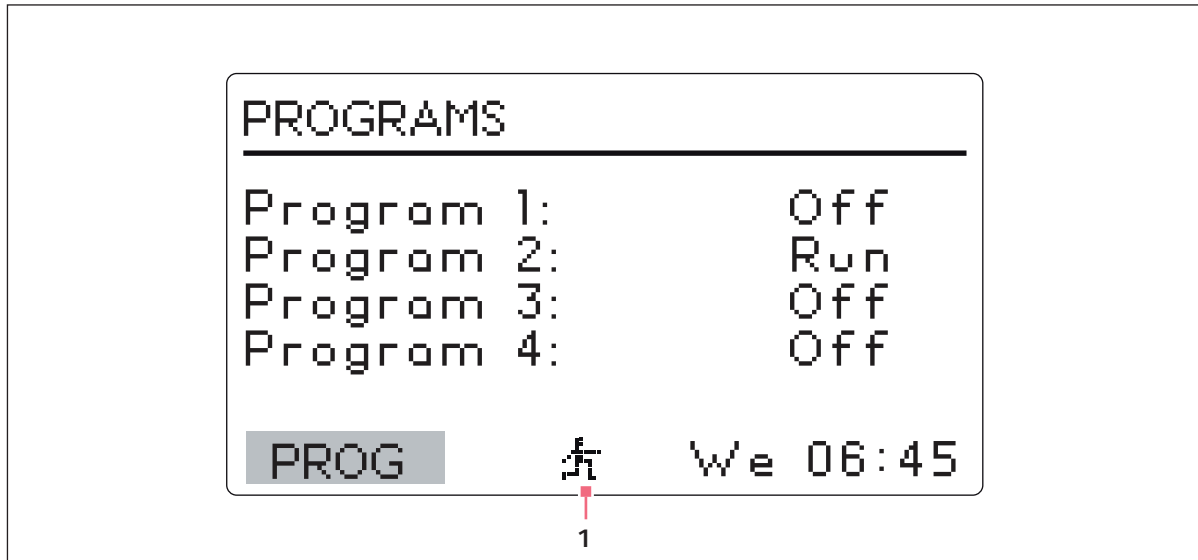

Fig. 5-15: Programs Screen, Running

#### 1 Run Icon

**To stop a program:** You can abort a run any time by changing the program's function to **Off**.

## 5.9 Mute the audible alarm

The Innova 42/42R shakers have an audible alarm that is activated under predetermined conditions (see *Alarms on p. 19*). It may be muted in the following way:

1. Turn the Control Knob until the **SET** screen is highlighted on the display. Click the Control Knob in to work in this screen.
2. Turn the Control Knob to highlight the **Mute** mode (**On**), then click the Control Knob in. The field will flash.
3. Turn the Control Knob to change the setting to **Off**, then click the Control Knob to save this selection.

To reactivate the audible alarm at any time, repeat steps 1 – 3, reversing "off" and "on".



## 5.10 Temperature offset calibration

The temperature probe and the temperature controller are calibrated together at the factory. The temperature probe measures the temperature of the air at the probe's location, near the return vent. The controller uses the probe input to adjust air temperature, up or down, to match the temperature setpoint.

Depending on various conditions within the chamber, such as flask placement and size, the heat produced by growing organisms, heat losses due to liquid evaporation from flasks, etc., the display temperature may differ from temperatures within the flasks themselves. You can calculate the correction value for this offset and program the shaker to display a corrected temperature.

### 5.10.1 Calculate the offset value

If you wish to have the temperature display ("Indicated Temperature") match the temperature at a given point, or match the average of a series of points within the chamber ("Actual Temperature"), proceed as follows:

1. Let the unit equilibrate at or near the desired temperature, then record the Indicated Temperature.
2. Now record the Actual Temperature.
3. Calculate the temperature correction value using this formula: Actual Temperature – Indicated Temperature = Temperature Offset Value.
4. To set the Temperature Calibration Offset, follow the procedure outlined in the next Section below.

### 5.10.2 Set the offset

#### To set the temperature calibration Offset:

1. Use the Control Knob to enter the **CAL** screen (see Fig. 5-16 on p. 58).
2. Turn the Control Knob to highlight the current setting (**0.0** in the sample screen above), then click the Control Knob in.  
The current setting will flash.
3. Turn the Control Knob (left for negative settings or right for positive settings) to display the desired setting. As you turn the Control Knob, each click represents 1 tenth of a degree Celsius (0.1 °C).
4. When you reach the desired setting, click the Control Knob in to save the new value.
5. When the Temperature Offset is set to any value other than 0, the asterisk icon will appear next to °C in the **DISP** and **SUMM** screens.



If you highlight an item, change it, but do not save your selection, after a few seconds the screen will revert to its previous setting.

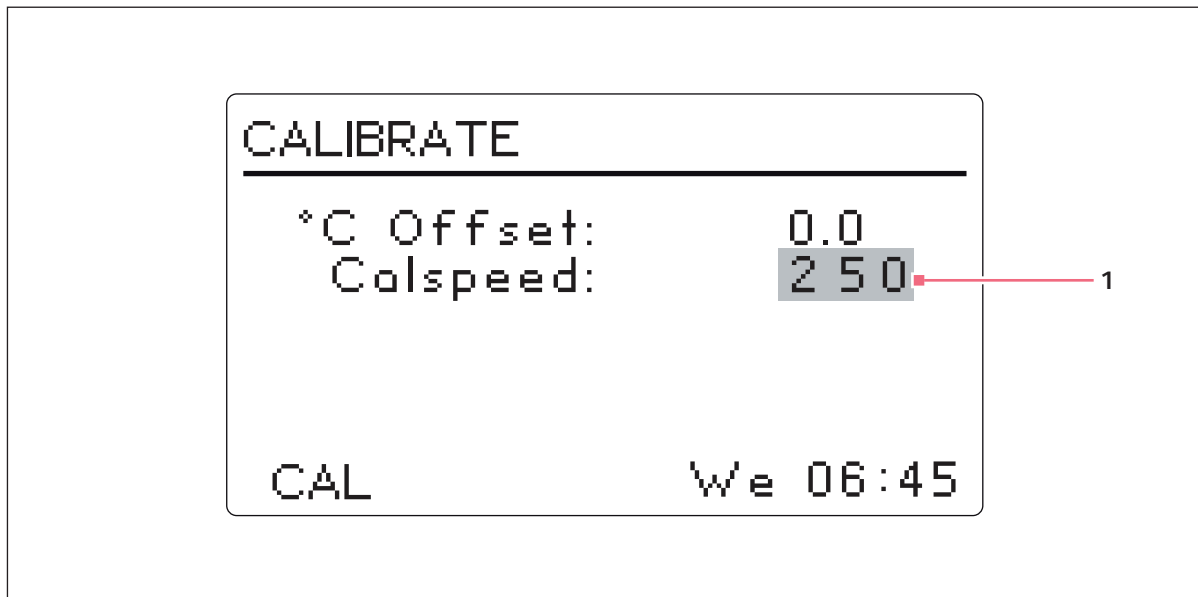

Fig. 5-16: Calibrate Screen

**1 This is a sample of the indicated rpm value.**

## 5.11 Using Calspeed

The Calspeed function, which is set in the **CAL** screen (see Fig. 5-16 on p. 58), is used to calibrate the speed of the shaking mechanism. Calibrated at the factory, speed does not need to be recalibrated until a major operating component (e.g., drive belt) is changed.



Prior to calibrating the speed, make sure that the platform is properly secured to the subplatform, and any flasks present are secured.

When the shaker is running, the **CAL** screen shows the indicated rpm value. If you wish to calibrate the speed, set the speed to a value that can be measured, a setpoint of 250 rpm works well. The use of a strobe is recommended for accuracy. If, after measuring the actual speed, you wish to adjust the indicated value:

1. Click the Control Knob in.
2. Set the new value.
3. Click the Control Knob in again to save the setting.
4. Turn the shaker OFF, wait a few seconds, then turn the shaker back ON.
5. Recheck the speed using a strobe.

## 5.12 Power interruption

In the event of a power failure, the Innova 42/42R Shakers are equipped with an automatic restart function. The shaker's non-volatile memory retains all stored information. If the shaker was in operation prior to the power interruption, the shaker will begin to operate at its last entered setpoints. The alarm/POWER display will flash, indicating that a power interruption has occurred. Turn the Control Knob in any direction to acknowledge the visual alarm. The flashing will stop.

**Operation**

New Brunswick™ Innova® 42/42R Shaker  
English (EN)

## 6 Troubleshooting

### 6.1 General troubleshooting

If any problems occur with your shaker, do not attempt to perform any service on the unit other than specified in this manual. Unauthorized servicing may void the warranty. Please contact your local Eppendorf Customer Service Department.

In any correspondence with Eppendorf, please refer to the model number and serial number of your unit. This information is on the electrical specification plate, located on the rear panel of the unit, above the power connector.

There are some problems, however, that you can investigate and correct yourself. Refer to the following Troubleshooting Guide:

Symptoms	Probable Causes and Solutions
Shaker does not run.	Power cord is not plugged in and/or power switch is off: plug in power cord (to working electric outlet), and turn on power switch.
	Door is open, look for Open Door icon on display: close door firmly.
	On/Off switch is not working: call for service.
	If you recently replaced a fuse, it may not have been seated properly: remove and reinstall the fuse carefully.
	Shaking speed has been set to Zero by program running (look for Run icon in display) or by computer interface: reset shaking speed.
	Defective main board: call for service
	Defective display controller board: call for service.
	Jammed shaking mechanism: call for service
	Defective motor: call for service
	Drive belt out of alignment or worn: call for service.
Shaker runs slowly and/or no speed indication.	If you recently replaced a fuse, it may not have been seated properly: remove and reinstall the fuse carefully.
	Incorrect speed calibration: recalibrate shaking speed.
	Defective main board: call for service.
	Defective motor: call for service.
Shaker does not run at set speed.	Drive belt out of alignment or worn: call for service.
	Shaker is running in Program mode (look for Run icon in display).
	Shaker speed has been changed by RS-232 command/ computer interface.
	Shaker is overloaded and/or you are using baffled flasks: remove some contents and balance load.
	Defective motor: call for service.
	Drive belt out of alignment or worn: call for service.
Check speed calibration.	

**Troubleshooting**

New Brunswick™ Innova® 42/42R Shaker  
English (EN)

Operating noise	Load out of balance: unload all contents, then reload.
	Loose component(s) in platform, subplatform and/or drive assembly: call for service.
Incubator does not reach set temperature.	Shaker running in Program mode: Run icon in display.
	Temperature setpoint changed by RS-232/computer interface command.
	Heater fuse blown: replace.
	Compressor fuse blown: replace.
	Compressor over-pressure switch activated: call for service.
	Ambient temperature too high or too low: cool or heat the room as needed.
	Defective heater: call for service.
	Defective refrigeration system: call for service.
Incorrect temperature indication (see below).	
Incorrect temperature indication.	Temperature Offset has been programmed: Offset icon in display.
	Defective RTD assembly: call for service.
	Defective main board: call for service.

## 7 Maintenance

### 7.1 Routine maintenance

No routine maintenance schedule is required for the Innova 42 and 42R.



#### **WARNING! Personnel injury and equipment damage!**

- ▶ When cleaning the unit, always turn off the shaker and disconnect the power cord from the power supply.
- 

To ensure that your shaker retains its attractive appearance, an occasional cleaning, using a cloth with conventional household (non-abrasive) cleaner is recommended (see *Cleaning external and internal surfaces on p. 63*).

We recommend you occasionally wipe down the shaker with a non-abrasive household cleaner.

We also suggest that the area around the shaker be vacuumed or swept to remove dust and other debris, ensuring proper air flow in and around the shaker.

### 7.2 Cleaning external and internal surfaces



#### **WARNING! Personnel injury and equipment damage!**

- ▶ When cleaning the unit, always turn off the shaker and disconnect the power cord from the power supply.
- 

The unit may be cleaned using a damp cloth or any standard household or laboratory cleaner to wipe down its outer surfaces. Do not use abrasive or corrosive compounds to clean this instrument, as they may damage the unit.

### 7.3 Biohazard decontamination

It is the responsibility of the user to carry out appropriate decontamination procedures if hazardous material is spilled on or inside the equipment. Before using any cleaning or decontamination method other than those suggested by the manufacturer, users should check with Eppendorf that the proposed method would not damage the equipment.

Commercially available household bleach solutions, when diluted at a 1:10 ratio, are effective in routine decontamination of the instrument. The method for decontaminating a spill depends upon the nature of the spill.

**Maintenance**

New Brunswick™ Innova® 42/42R Shaker  
English (EN)

Spills involving fresh cultures or samples known to have low concentrations of biomass should be flooded with decontamination solution and soaked for 5 min before cleanup. Spills involving samples with high concentrations of biomass, or involving organic matter, or occurring in areas warmer than room ambient temperature, should be exposed to decontamination solution for at least 1 hour before cleanup.

**WARNING! Personnel injury!**

- ▶ Personnel involved in the cleanup of any spill should wear gloves, safety glasses, and a laboratory coat or gown during the cleanup process. Respiratory protection should be considered for spills where aerosolization is suspected.
-



## 8 Technical data

### 8.1 Specifications

 The use of baffled flasks will significantly reduce maximum speed for any shaker.

These specifications assume a maximum load of 15.5 kg (34 lb), including platforms, clamps, glassware, and contents.

#### 8.1.1 Shaking

Speed	<ul style="list-style-type: none"> <li>• 25 rpm – 400 rpm</li> </ul>
Control accuracy	<ul style="list-style-type: none"> <li>• <math>\pm 1</math> rpm</li> </ul>
Stroke	<ul style="list-style-type: none"> <li>• 1.9 cm (3/4 in)</li> <li>• 2.54 cm (1 in)</li> </ul>
Indication	<ul style="list-style-type: none"> <li>• Displayed in 1 rpm increments</li> </ul>
Alarm signal	<ul style="list-style-type: none"> <li>• Visible and audible alarm when speed deviates <math>\pm 5</math> rpm from setpoint</li> </ul>
Drive mechanism	Triple-eccentric counterbalanced drive with 9 permanently lubricated ball bearings
Safety	Drive Interrupt shuts off power to Shaker when door opens. Acceleration/deceleration circuit prevents sudden starts and stops, minimizing both splashing and mechanical damage. Independent mechanical sensing switch also shuts the motor off in unbalanced condition.

#### 8.1.2 Temperature control

Heaters	Long-life, low-watt density resistance-type heater with high temperature thermostat
Control accuracy	<ul style="list-style-type: none"> <li>• <math>\pm 0.1</math> °C at 37°C</li> <li>• <math>\pm 0.5</math> °C over the remaining range</li> </ul>
Temperature range (42)	<ul style="list-style-type: none"> <li>• 5 °C above ambient temperature to 80 °C</li> </ul>
Temperature range (42R)	<ul style="list-style-type: none"> <li>• 20 °C below ambient temperature (minimum 4 °C) to 80 °C</li> </ul>
Alarm signal	<ul style="list-style-type: none"> <li>• Visible and audible alarm when temperature deviates <math>\pm 1</math> °C from setpoint</li> </ul>

**Technical data**

New Brunswick™ Innova® 42/42R Shaker  
English (EN)

**8.1.3 Power supply**

<ul style="list-style-type: none"> <li>• 100 V 50/60 Hz</li> <li>• 120 V 60 Hz</li> <li>• 230 V 50 Hz</li> </ul>	1500 VA
--	---------

**8.1.4 Dimensions**

	<b>Width</b>	<b>Depth</b>	<b>Height</b>
Space requirements	84 cm (33 in)	85 cm (33.5 in)	84 cm (33 in)
Dimensions	63.5 cm (25 in)	74.5 cm (29.3 in)	81.8 cm (32.2 in)
Chamber dimensions	51.7 cm (20.4 in)	51.5 cm (20.3 in)	47.7 cm (18.8 in)
Platform dimensions	46 cm (18 in)	46 cm (18 in)	

**8.1.5 Weight**

42	98 kg (216 lb)
42R	121 kg (266 lb)

**8.1.6 Ambient conditions**

Ambience	Only for use indoors
Ambient temperature	10 °C – 35 °C
Relative humidity	20 % – 80 % (non-condensing)
Altitude	Up to 2000 m

**8.1.7 CE regulatory standards**

For CE regulatory standards, see p. 87.

**8.1.8 ETL regulatory standards**

UL 61010A-1	CAN/CSA-C22.2 No. 1010.1
UL 61010A-2-010	CAN/CSA-C22.2 No. 1010.2.010

### 8.1.9 Features

Alarms	Visible and audible warning indication when speed deviates more than 5 rpm or temperature more than 1 °C from setpoints, and when timer has expired. Audible alarm can be muted.
Display	240 x 128 backlit
RS-232	Remote control, remote monitoring, remote data logging.
Setpoint retention	All setpoints and operating status are retained in non-volatile memory.
Automatic restart	Automatic restart after power is restored, indicated by flashing display.

### 8.1.10 Fuses

**Behind Electrical Panel:**

- 3.15 A glass tube, slow-blowing
- 8.0 A glass tube, slow-blowing
- 10.0 A glass tube, slow-blowing

**Next to Outlet:**

- 0.5 A glass tube, slow-blowing
- 0.75 A glass tube, slow-blowing
- 1.0 A glass tube, slow-blowing

## 8.2 Load/speed graphs

In the following graphs, 20 % and 50 % indicate level to which flasks were filled. These are sample load/speed runs provided for your information.

**Technical data**

New Brunswick™ Innova® 42/42R Shaker  
English (EN)

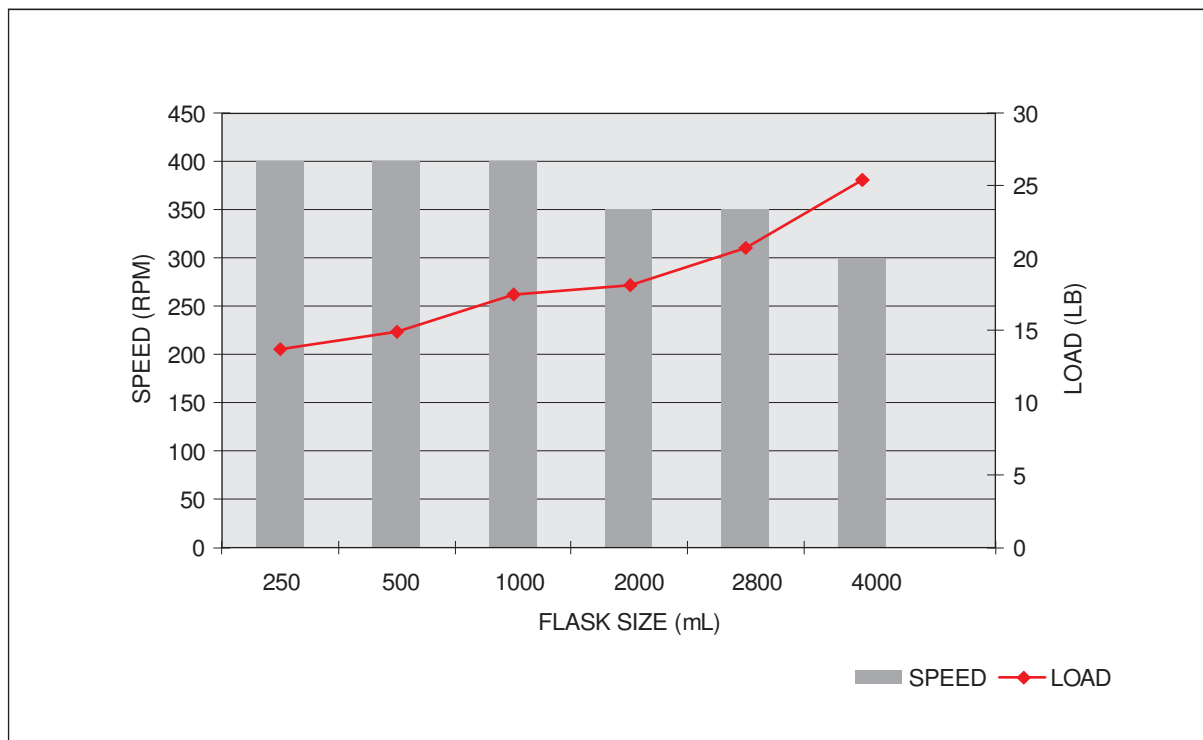

Fig. 8-1: Innova 42 with 2.54 cm (1 in) orbit - 20 %

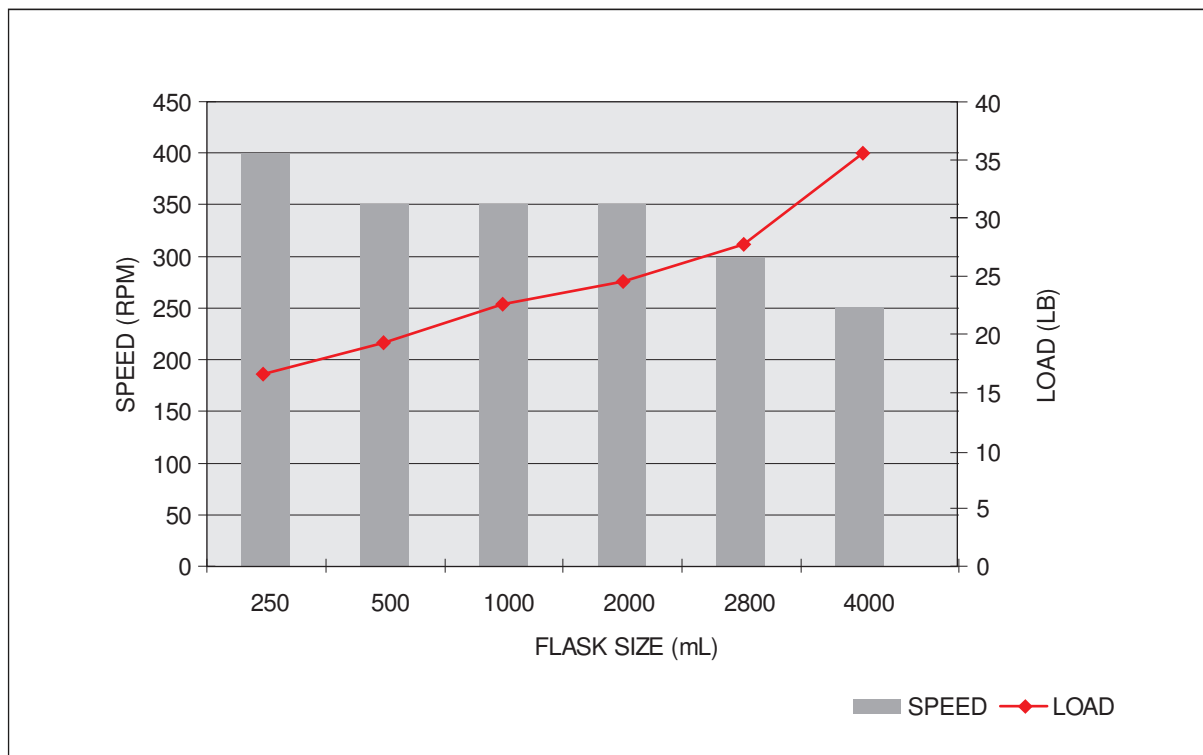

Fig. 8-2: Innova 42 with 2.54 cm (1 in) orbit - 50 %

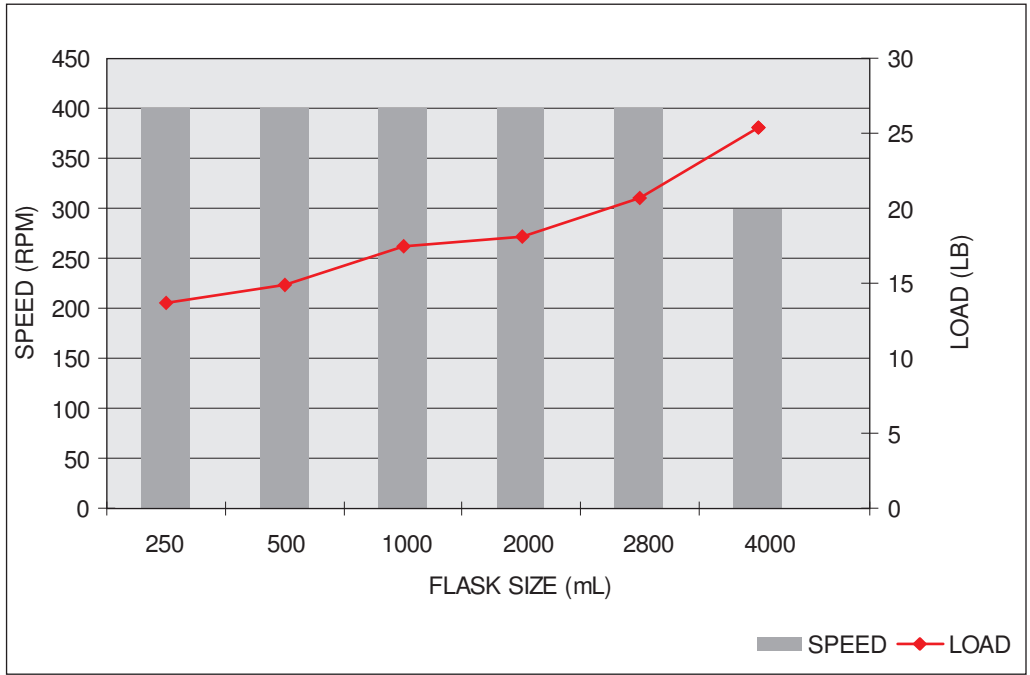

Fig. 8-3: Innova 42R with 1.9 cm (3/4 in) orbit - 20 %

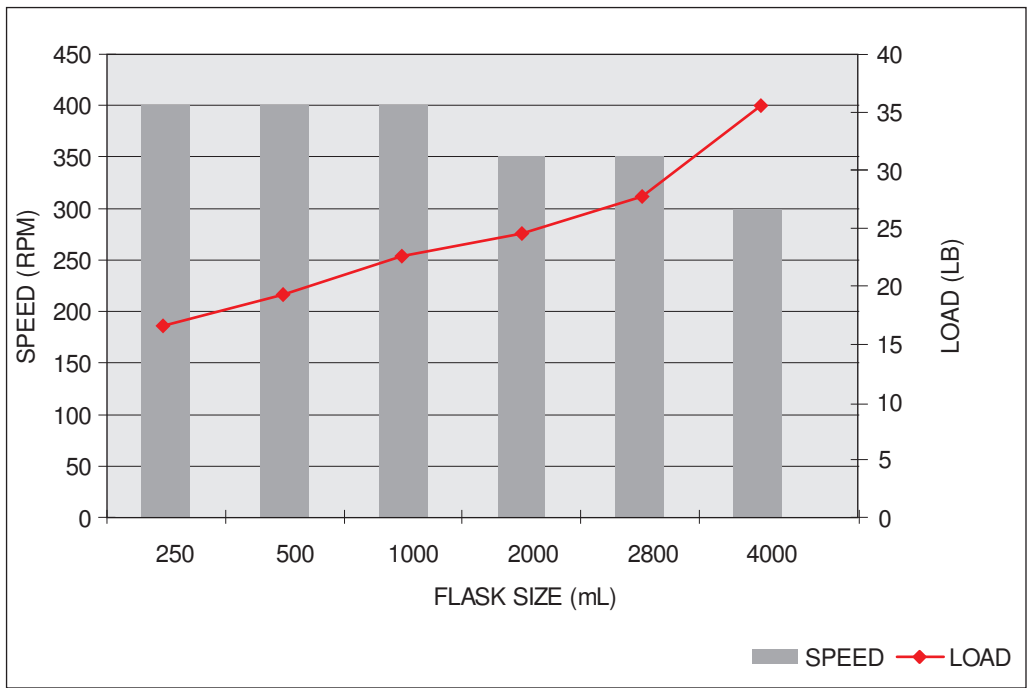

Fig. 8-4: Innova 42R with 1.9 cm (3/4 in) orbit - 50 %

**Technical data**

New Brunswick™ Innova® 42/42R Shaker  
English (EN)

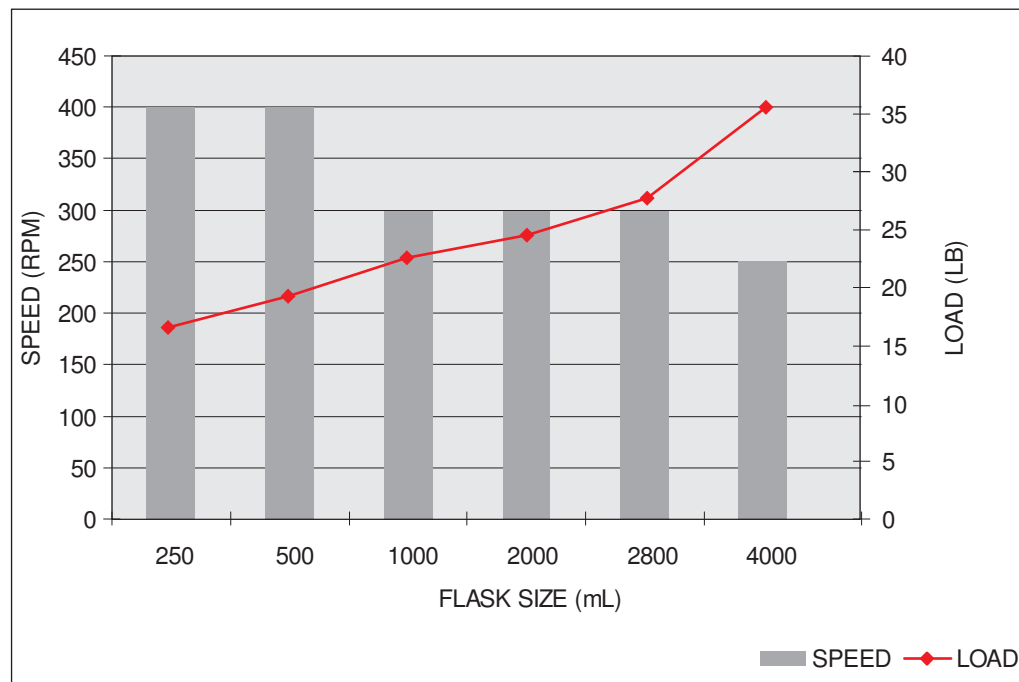

Fig. 8-5: Innova 42 and 42R stacked

### 8.3 Using ancillary equipment with the Innova 42/42R

The Innova 42/42R has a special internal AC socket, rated at 100 W, that is used to power ancillary equipment such as magnetic stirrers, rockers, rollers or small shakers.

In most cases, the equipment used will be light duty rockers or rollers. However, if heavier equipment is desired, the operator should verify that the stainless steel shelves supplied can support the load.

In addition, be sure to verify that the equipment operating inside the Innova 42/42R does not affect the stability of the unit. This is accomplished by operating the particular piece of equipment under the expected load and speed conditions. If the Innova 42/42R vibrates, limit the load and/or speed conditions for the operation of the ancillary equipment.

If the Innova 42/42R is intended to be used as a shaker at the same time, both shaker and ancillary equipment should be run under expected load and speed conditions. If the unit vibrates, the shaker speed and/or the load should be reduced, or the Innova 42/42R should not be used as a shaker at the same time the ancillary device is in operation.

The outlet is located inside the shaker chamber on the upper left side. It is important to note that this AC supply is the same as the main supply of your 42/42R. If your unit operates off a 120 V supply, then any ancillary equipment you plug into the internal socket must also operate at 120 V.

### 8.3.1 Electrical moisture-proof plug

The AC socket (see Fig. 8-6 on p. 71), with cover and mating plug (supplied) is designed to be used in humid environments. To use the socket, you have to connect the special male plug (supplied with the unit) to the equipment that you use in the Innova 42/42R. If your equipment has a detachable power cord, you may want to obtain a different power cord to be used solely with the Innova 42/42R shaker.

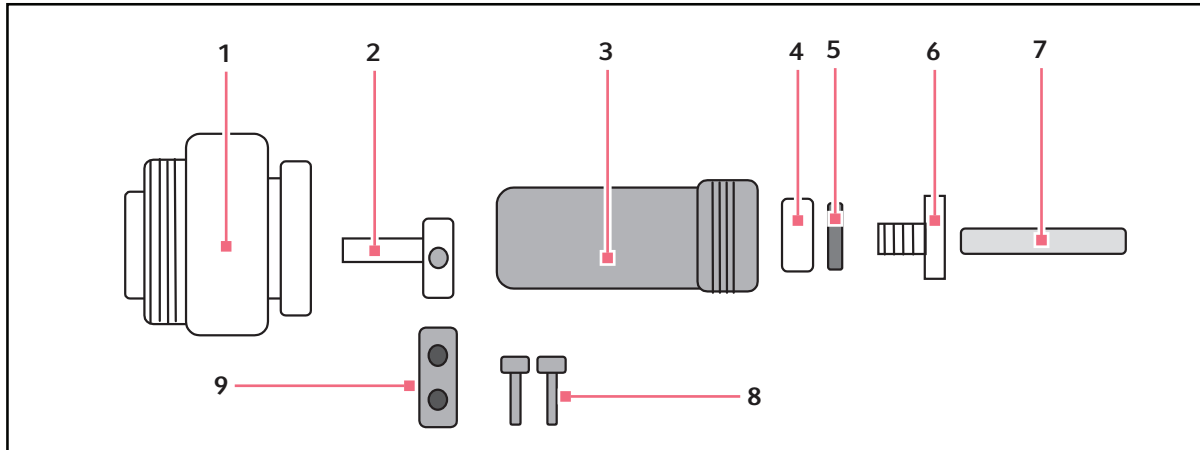

Fig. 8-6: Internal AC Moisture-Proof Plug

- |                  |                 |
|------------------|-----------------|
| 1 Terminal Block | 6 Plastic Nut   |
| 2 Strain Relief  | 7 Power Cord    |
| 3 Main Body      | 8 2 Screws      |
| 4 Rubber Grommet | 9 Metal Bracket |
| 5 Washer         |                 |



**WARNING! Personnel injury and equipment damage!**

- ▶ The following procedure is to be performed ONLY by an authorized service technician.



**WARNING! Personnel injury and equipment damage!**

- ▶ The internal AC circuit supplied is fused at 100 Watts. DO NOT connect other equipment that requires more power.



**WARNING! Personnel injury and equipment damage!**

- ▶ The protective cover attached to the internal AC socket MUST always cover the socket when the socket is not being used. Verify the power is off before you attach or detach the cover.

**Technical data**

New Brunswick™ Innova® 42/42R Shaker  
English (EN)

**To assemble the moisture-proof plug:**

1. Connect the power cord to the electrical plug. Slide the power cord through the plastic nut, washer, rubber grommet and the main body (see Fig. 8-6 on p. 71).
2. Connect the hot wire to terminal 2.
3. Connect the neutral wire to terminal 3.
4. Connect the ground wire to the ground terminal on the terminal block.
5. Attach the strain relief to the terminal block. Slide the 2 legs into the slots in the terminal block.
6. Use the metal bracket, capture the wires and secure with the 2 screws.
7. Screw the main body onto the terminal block.
8. Push the rubber grommet into the end of the main body.
9. Push the washer on.
10. Screw the plastic nut onto the main body and tighten. Ensure a tight seal by hand tightening the rubber grommet to compress the power cord. Securely tightening the plastic nut to the main body also provides a water seal for the plug.
11. Connect the power cord to the ancillary equipment if applicable.
12. Turn off all the power switches.
13. Remove the cover to the internal socket. The socket is on the upper right side inside the shaker chamber.
14. Plug the electrical plug into the internal socket, and secure the plug in place by hand tightening the knurled knob.



The socket is keyed so that it will only go in when oriented properly.

15. Use the knurled knob and tighten the plug finger tight to obtain a good seal.

Your ancillary equipment operates whenever the main power switch is powered on.



Use of ancillary equipment in the Innova 42/42R may affect the operating temperature range of the Innova 42/42R. This is due to the additional heat generated by the ancillary equipment used.



The internal AC socket is also used for the factory-installed optional photosynthetic lamps. If this option is installed on your shaker(s), the internal socket cannot be used for other equipment.



## 9 Ordering information

### 9.1 Replacement parts

Eppendorf offers a spare parts kit, part number M1335-6000, that contains commonly needed replacement parts for your Innova 42/42R shaker: 1 motor drive poly-V belt, 2 light bulbs and various fuses.

### 9.2 Accessories

When ordering accessories, you may be asked to provide the model number and serial number of your shaker. This information is on the electrical specification plate, located on the rear panel of the unit.

#### 9.2.1 Platforms

Tab. 9-1: Available Platforms

Description	Capacity	Part Number
Universal Platform	(see Tab. on p. 73)	M1250-9902
125 mL Erlenmeyer flask Dedicated Platform <sup>1</sup>	34	M1194-9904
250 mL Erlenmeyer flask Dedicated Platform <sup>1</sup>	25	M1194-9905
500 mL Erlenmeyer flask Dedicated Platform <sup>1</sup>	16	M1194-9906
1 L Erlenmeyer flask Dedicated Platform <sup>1</sup>	9	M1194-9907
2 L Erlenmeyer flask Dedicated Platform <sup>1</sup>	5	M1194-9908
2.8 L Fernbach flask Dedicated Platform <sup>1</sup>	4	M1233-9932
Utility carrier with cushioned crossbars	–	M1194-9909
Utility tray with non-skid rubber surface	–	M1194-9910
Sticky pad platform	–	M1250-9903

<sup>1</sup>Dedicated Platforms include flask clamps

Tab. 9-2: Platform Capacity Chart

Innova Model	42/42R	
Platform (cm and in)	46 cm x 46 cm 18 in x 18 in	
Dedicated Platform (D) Universal Platform (U)	D	U
10 mL	–	109
25 mL	–	64
50 mL	64	45
125 mL	34	21
250 mL	25	18
500 mL	16	14

**Ordering information**

New Brunswick™ Innova® 42/42R Shaker  
English (EN)

1 L	9	8
2 L	5	5
2.8 L	4	4
4 L	4	4
Large TT Rack	–	4
Medium TT Rack	–	5
Small TT Rack	–	5
Microplate Rack (stack)	–	8
Microplate Rack (1 layer)	–	2

### 9.2.2 Flask clamps for universal platforms

The following clamps, according to flask size, are available for use with the Universal Platform:

Tab. 9-3: Flask Clamps

Clamp Size	Part Number
10 ml Erlenmeyer Flask	ACE-10S
25 ml Erlenmeyer Flask	M1190-9004
50 ml Erlenmeyer Flask	M1190-9000
125 ml Erlenmeyer Flask	M1190-9001
250 ml Erlenmeyer Flask	M1190-9002
500 ml Erlenmeyer Flask	M1190-9003
1 L Erlenmeyer Flask	ACE-1000S
2 L Erlenmeyer Flask	ACE-2000S
2.8 L Fernbach Flask	ACFE-2800S
3 L Erlenmeyer Flask	ACE-3000S
4 L Erlenmeyer Flask	ACE-4000S

### 9.2.3 Replacement clamp hardware

Eppendorf flask clamps come complete with mounting screws. Additional screws are available separately in packs of 25 (Part number S2116-3051P).

9.2.4 Test tube racks and other accessories

Tab. 9-4: Racks and Trays

Accessory Description	Part Number	Platform Capacity	
Adjustable angle Test Tube Rack for tubes 8 mm – 11 mm diameter	80 tube capacity	M1289-0100	7
	60 tube capacity	M1289-0010	9
	48 tube capacity	M1289-0001	9
Adjustable angle Test Tube Rack for tubes 12 mm – 15 mm diameter	60 tube capacity	M1289-0200	7
	44 tube capacity	M1289-0020	9
	34 tube capacity	M1289-0002	9
Adjustable angle Test Tube Rack for tubes 15 mm – 18 mm diameter	42 tube capacity	M1289-0300	7
	31 tube capacity	M1289-0030	9
	24 tube capacity	M1289-0003	9
Adjustable angle Test Tube Rack for tubes 18 mm – 21 mm diameter	30 tube capacity	M1289-0400	7
	23 tube capacity	M1289-0040	9
	18 tube capacity	M1289-0004	9
Adjustable angle Test Tube Rack for tubes 22 mm – 26 mm diameter	22 tube capacity	M1289-0500	7
	16 tube capacity	M1289-0050	9
	13 tube capacity	M1289-0005	9
Adjustable angle Test Tube Rack for tubes 26 mm – 30 mm diameter	20 tube capacity	M1289-0600	7
	16 tube capacity	M1289-0060	9
	12 tube capacity	M1289-0006	9
Microplate holder rack (stacked)	3 deep well or 9 standard	M1289-0700	16
Microplate holder rack (single layer)	5 deep well or standard	TTR-221	4
Angled Test Tube Rack Holder <sup>1</sup> for user-supplied test tube racks that are 10 cm – 13 cm (4 in – 5 in) wide and up to 38 cm (15 in) long.		TTR-210	4
Angled Test Tube Rack Spacer Bar <sup>1</sup> for use with TTR-210 to accommodate test tubes racks that are less than 13 cm (5 in) wide.		TTR-215	NA

<sup>1</sup>Universal Platform Required

**Ordering information**

New Brunswick™ Innova® 42/42R Shaker  
English (EN)

## 10 Transport, storage and disposal

### 10.1 Transport and storage

When transporting or storing the device, always use the original packaging material.

### 10.2 Disposal

In case the product is to be disposed of, the relevant legal regulations are to be observed.

#### **Information on the disposal of electrical and electronic devices in the European Community:**

Within the European Community, the disposal of electrical devices is regulated by national regulations based on EU Directive 2012/19/EU pertaining to waste electrical and electronic equipment (WEEE).

According to these regulations, any devices supplied after August 13, 2005, in the business-to-business sphere, to which this product is assigned, may no longer be disposed of in municipal or domestic waste. To document this, they have been marked with the following identification:



Because disposal regulations may differ from one country to another within the EU, please contact your supplier if necessary.

In Germany, this is mandatory from March 23, 2006. From this date, the manufacturer has to offer a suitable method of return for all devices supplied after August 13, 2005. For all devices supplied before August 13, 2005, the last user is responsible for the correct disposal.

**Transport, storage and disposal**

New Brunswick™ Innova® 42/42R Shaker  
English (EN)

## 11 Appendix A: Remote programming

### 11.1 Setting up with HyperTerminal



HyperTerminal is only present in Microsoft® Windows XP and older.

You can use the Microsoft HyperTerminal program on your personal computer to communicate with your shaker:

1. Before you set up HyperTerminal, be sure to check the Mode and Baud Rate parameter settings (see *RS232 screen on p. 48*).
2. While you are in the RS232 screen (see Fig. 5-8 on p. 49), set the Mode parameter to Slave, and select the appropriate Baud Rate. The default setting, as you see in your screen, is 19200; your other choices are 9600 or 38400.
3. Connect the RS-232 cable between your computer and the shaker’s RS-232 port (see Fig. 3-3 on p. 16).
4. Start HyperTerminal, and follow the steps for Setting a New Connection. When prompted, select the COM port you will be using, then set the COM parameters (see Table below):
5. To be sure that you have established a connection with your shaker, turn the shaker OFF, open the HyperTerminal connection, then turn the shaker back ON. Once a connection has been made, the shaker will send an OK to HyperTerminal.
6. You may wish to send a trial command to the shaker (see Sample Test below). We suggest that you enable Caps Lock on your computer, because all commands must be sent as capital letters.

Tab. 11-1: COM Parameters for HyperTerminal

Baud Rate	Enter the setting on your shaker (see Step 2 above)
Data Bits	8
Parity	None
Stop Bits	1
Flow Control	None

#### Sample Test:

1. To request the current setpoint, type **RS** at the terminal. When you type **R**, you should see the **R** on the computer display. This is an echo character, sent back by the Innova 42/42R. When you type the **S**, you should see the echo **S** displayed at the computer.
2. Use the **Enter** key to send the carriage return control character. This will move the cursor back over the first character.
3. **RS** is a Request command, so your shaker will send back the data corresponding to the command.

### 11.2 Overview of command sets

Using an optional RS-232 interface, the user has the capability to control various functions of the Innova 42/42R shakers by computer. A detailed command set follows this introduction.

## Appendix A: Remote programming

New Brunswick™ Innova® 42/42R Shaker  
English (EN)

The serial interface uses an echo character protocol Setting that is implemented to indicate that a valid character has been received by the shaker. For every character sent by the user computer, the Innova 42/42R will return a matching character. This echo character should be read by the computer and compared to the character that was sent.



When you are sending a command, do not allow the pause between any 2 characters of your message to last longer than 10 s. If it takes any longer, the shaker's serial port will reset itself.

In the following example, the Master (your computer) will command (the **C** in **CS**) the shaker (Slave) to set its speed to **150 RPM**:

Master sends:	Innova 42/42R responds:
CS<Space>150<CR>	CS<Space>150<CR>

In the next example, the Master (your computer) will request that the shaker (Slave) report (the **R** in **RV**) the actual parameters:

Master sends:	Innova 42/42R responds:
RV<CR>	First the echo: RV<CR>
	Then the report: <Arg1><Tab><Arg2><Tab><Arg3>...<Arg7><CR><LF>



On power-up, even if the shaker is not set in Slave mode at the time, the shaker will always send these 4 characters: OK<CR><LF>. Before starting any communications, be sure to clear the computer's receive buffer.

This is the command set format:

<Command><Space><Arg1><Space><Argn...><Terminator>

Most Commands are defined as 2 capital characters using standard ASCII format (see the command sets provided below).

If a command has additional arguments, the ASCII space control character separates each argument. The command is terminated using the ASCII carriage return control character; an optional line feed control character may also be included but must follow the carriage return character.

When a command is sent that returns data, the characters returned are in ASCII format. Each additional argument returned will be separated by the ASCII space or tab control character; refer to the selected command for the actual format. Data returned is terminated with a carriage return line feed control character sequence.

The next section provides an Index to the 2 character command codes.

The next 4 sections provide command sets for your use for Set Commands, Profile Control Commands, Report Request Commands and Set/Get Date & Time.



### 11.3 Index to command codes

Command Code	Meaning
CS	Command Speed
CT	Command Temperature
PC	Clear Profile
PM	Profile Mode
PR	Read Profile Step in Memory
PS	Profile Stop/Start
PW	Write Profile Step to Memory
RI	Report Software Version
RP	Report Parameter List
RS	Report Setpoint Values
RV	Report Measured Values
=D	Set Date and Time
?D	Get Date and Time

### 11.4 Set commands

Code	Meaning	Format
CS	Command Speed	CS<Space><Arg1><CR> where Arg1= Agitation setpoint (####)
CT	Command Temperature	CT<Space><Arg1><CR> where Arg1= Temperature setpoint (###.#)

### 11.5 Profile control commands

Code	Meaning	Format
PC	Clear Profile (clears profile step)	PC<Space><Arg1><Space><Arg2><CR> where Arg1= Profile number (range 1 to 4) and Arg2=Step number (range 1 to 15) NOTE: If Arg2 is not included, all 15 steps of the selected profile will be cleared.

PM	Profile Mode (returns status of current profile run/hold mode)	PM<CR> There are no parameters to this command. Return data format: <Arg1><Space><Arg2><Space><Arg3><CR> where Arg1=Run/hold status (0 = end, 1 = run), Arg2=Profile number and Arg3=Step number NOTE: If a profile has not been selected to run, a 0 will be returned for Profile number and Step number.
PR	Read Profile step in memory	PR<Space><Arg1><Space><Arg2><CR> where Arg1=Profile number (range 1 to 4) and Arg2=Step number (range 1 to 15) Return data format: <Arg1><Space><Arg2><Space><Arg3><Space>...<CR><LF> where Arg1=Profile number (range 1 to 4), Arg2=Step number, Arg3=Temperature setpoint, Arg4=Agitation setpoint, Arg5=CO2 setpoint (future option, reads 0.0), Arg6=Step hours, and Arg7=Step minutes
PS	Profile Stop/Start (stops or starts a program profile)	PS<CR> With no other parameters, any profile currently running will be stopped. PS<Space><Arg1><Space><Arg2><CR> where Arg1=Profile number (range 1 to 4), and Arg2=Step number (range 1 to 15). NOTE: If Arg2 is not included, the profile will start in Step 1.
PW	Write Profile step to memory	PW<Space><Arg1><Space><Arg2><Space><Arg3><Space>...<CR> where Arg1=Profile number (range 1 to 4), Arg2=Step number (range 1 to 15), Arg3=Temperature setpoint, Arg4=Agitation setpoint, Arg5=CO2 setpoint (future option); Enter 0.0, Arg6=Step hours (range 0 to 99) and Arg7=Step minutes (range 0 to 59)

## 11.6 Report request commands

Code	Meaning	Format
RI	Report Software Version	RI<CR> Return data format: <Arg1><Tab><Arg2><CR><LF> where Arg1=Display module software version, and Arg2=Control module software version
RP	Report Parameter List (ASCII text header)	RP<CR> Return data format: <Arg1><Tab><Arg2><Tab><Arg3>...<Arg6><CR><LF> where Arg1="Shaker Speed", Arg2="Temperature" and Arg3="% CO2 Concentration"

RV	Report Measured Values	RV<CR>
RS	Report Setpoint Values	RS<CR> Return data format: <Arg1><Tab><Arg2><Tab><Arg3>...<Arg6><CR><LF> where Arg1= Shaker Speed, Arg2=Temperature, and Arg3=% CO2 Concentration (future option, reads 0.0)

### 11.7 Set/Get date and time

Code	Meaning	Format
=D	Set Date and Time	=D<Space><Arg1><Space><Arg2><Space><Arg3><Space><Arg4><Space><Arg5><Space><Arg6><Space><Arg7><CR>
?D	Get Date and Time	?D<CR> Return data format: <Arg1><Tab><Arg2><Tab><Arg3><Tab>...<Arg7><CR><LF> where Arg1=Hours (range 0-23), Arg2=Minutes (range 0-59), Arg3=Seconds (range 0-59), Arg4=Year (range 00-99), Arg5=Month (range 01-12), Arg6=Date (range 1-31), Arg7=Day (range 1-7; 1=Monday, 2=Tuesday...7=Sunday)

For example, this =D command:

```
=D<Space><01><Space><30><Space><00><Space><04><Space><07><Space><04><Space><07><CR>
```

will set the real date and time on your shaker to: 1:30:00 am, 2004, July 4, Sunday.

**Index****A**

Accessories.....	73
Alarms .....	19
Appendix A: Remote programming .....	79
ATEX Guideline .....	9
Automatic restart.....	59

**B**

Biohazard decontamination .....	63
---------------------------------	----

**C**

Calculate the offset value .....	57
Calibrate screen.....	50
Calspeed .....	58
Caution, explanation of .....	7
Changing screens .....	17
Cleaning .....	63
Controls .....	16
Create a program.....	52
Culture drawer.....	23, 29
Culture drawer installation.....	24

**D**

Danger, explanation of .....	7
Decontamination .....	63
Device overview	
Front view .....	13
Internal view .....	14
Rear view .....	13
Display icons .....	19
Display screen .....	41
Disposal.....	77
Door operation .....	20
Drain the drip pan reservoir .....	41

drip pan reservoir .....	40
--------------------------	----

**E**

Edit a program.....	55
Electrical connections.....	29
Electrical moisture-proof plug .....	71
Electrical requirements.....	26
Environment .....	26

**F**

Fill the drip pan reservoir .....	40
Flask clamp installation .....	27
Flask clamps for universal platforms.....	74

**G**

Gassing manifold kit.....	21
General troubleshooting .....	61
Germicidal UV lamp .....	22

**H**

Hazard symbols .....	7
Heater .....	20
Humidity monitor .....	22
HyperTerminal.....	79

**I**

Index to command codes.....	81
Inspection of boxes.....	25
Installation .....	25
Installation of platform .....	39
Intended use .....	9
Interior lamps .....	20

**L**

Lamps screen.....	47
-------------------	----

LCD Display ..... 17

**M**

Manual conventions ..... 8

Mute the audible alarm ..... 56

**N**

Name plate ..... 13

Notice, explanation of ..... 7

**O**

Optional culture drawer ..... 23, 29

Optional gassing manifold kit..... 21

Optional germicidal UV lamp..... 22

Optional humidity monitor ..... 22

Optional photosynthetic growth lamps ..... 22

Optional remote alarm ..... 21

Out of box concerns ..... 25

overview ..... 14

Overview of command sets ..... 79

**P**

Packing list ..... 25

Photosynthetic growth lamps..... 22

Physical location..... 25

Platform assemblies ..... 39

Platform installation ..... 27

Platforms ..... 73

Power failure ..... 59

Power interruption ..... 59

Product liability ..... 10

Profile control commands ..... 81

Programmed steps ..... 51

Programming the shaker..... 51

Programs screen ..... 51

**R**

Refrigeration..... 21

Remote alarm..... 21

Replacement clamp hardware ..... 74

Replacement parts ..... 73

Report request commands..... 82

Routine maintenance..... 63

RS-232 ..... 20

RS232 screen ..... 48

Run a program..... 56

**S**

Safety precautions ..... 40

Service accessibility..... 21

Set commands ..... 81

Set the offset..... 57

Set/Get date and time ..... 83

Setting up with HyperTerminal ..... 79

Setup screen ..... 46

Software interfaces ..... 20

Space requirements..... 26

Spill containment..... 20

spill cover..... 39

Stacking instructions ..... 30

Stacking Kit..... 30

Start the shaker..... 41

Summary screen ..... 44

Symbols used..... 8

**T**

Temperature offset calibration..... 57

Test tube racks and other accessories..... 75

Transport and storage..... 77

Troubleshooting..... 61

**Index**

New Brunswick™ Innova® 42/42R Shaker  
English (EN)

**U**

Unpacking of equipment.....	25
User requirement .....	9
Using ancillary equipment .....	70
Using Calspeed.....	58
Using the LCD screens .....	41
Using this manual .....	7

**W**

Warning, explanation of .....	7
-------------------------------	---

# Declaration of Conformity

The product named below fulfills the requirements of directives and standards listed. In the case of unauthorized modifications to the product or an unintended use this declaration becomes invalid.

**Product name:**

Innova® 42 / Innova® 42R

including accessories

**Product type:**

Laboratory Shaker

**Relevant directives / standards:**

2006/95/EC: EN 61010-1, EN 61010-2-010

2004/108/EC: EN 61326-1, EN 61000-3-2, EN 61000-3-3

2011/65/EU

2012/19/EU



Management Board



Portfolio Management

**Date:** September 30, 2013

Your local distributor: [www.eppendorf.com/contact](http://www.eppendorf.com/contact)  
Eppendorf AG · 22331 Hamburg · Germany  
[eppendorf@eppendorf.com](mailto:eppendorf@eppendorf.com)

ISO 9001  
Certified

ISO 13485  
Certified

ISO 14001  
Certified

Eppendorf and the Eppendorf Logo are registered trademarks of Eppendorf AG Hamburg/Germany.  
All rights reserved incl. graphics and pictures. Copyright 2013 © by Eppendorf AG.







# Evaluate Your Manual

Give us your feedback.  
[www.eppendorf.com/manualfeedback](http://www.eppendorf.com/manualfeedback)